

# Model 875 Single- and Multi-Channel Ultra-Agile Vector Signal Generator



## Features

- Excellent Phase Noise
- Ultra-Fast Switching
- Ultra High I/Q Data Rates, Deep Internal Memory
- Various Digital Modulation Supported

## Applications

- Arbitrary I/Q Waveform
- Radar Signal Simulation
- Receiver Testing
- Avionic Modulation Emulation
- High Speed Antenna Testing



## Model 875 Datasheet

10 MHz to 4, 6, 12, 20, and 40 GHz

# CONTENTS

<b>DEFINITIONS</b> .....	<b>4</b>
<b>INTRODUCTION</b> .....	<b>4</b>
<i>Ultra-Agile Vector Signal Generator</i> .....	4
<b>SPECIFICATIONS</b> .....	<b>5</b>
<i>Frequency Parameters / Range</i> .....	5
<i>Frequency Reference</i> .....	5
<i>Level Performance</i> .....	5
<i>Power Level Uncertainty</i> .....	7
<i>Reverse Power Protection and VSWR</i> .....	8
<i>Phase Noise</i> .....	8
<i>Spectral Purity</i> .....	10
<i>Sweeping Capability</i> .....	12
<i>Phase Coherence</i> .....	12
Phase-Coherent Modes.....	12
Multi-Channel Performance .....	14
Multi-Device Performance (Option SYNC).....	14
<i>Analog Modulation (Option MOD)</i> .....	15
Pulse Modulation .....	15
Amplitude Modulation .....	16
Frequency Modulation .....	17
Phase Modulation .....	18
<i>Pulse Descriptor Word (Option PDW)</i> .....	18
Mode Overview .....	18
<i>I/Q Modulator</i> .....	19
<i>Internal I/Q Baseband Generator</i> .....	20
<i>Internal Vector Modulation (Option IVM)</i> .....	20
<i>Multicarrier Generation (Option IVM)</i> .....	23
<i>DME Modulation (Option AVIO)</i> .....	24
<i>VOR Modulation (Option AVIO)</i> .....	24
<i>ILS Modulation (Option AVIO)</i> .....	25
<i>Marker Beacon (Option AVIO)</i> .....	27
<i>Additive White Gaussian Noise (Option AWGN)</i> .....	27
<i>Trigger Capability</i> .....	27
<i>External Multi-Function Inputs</i> .....	28
<i>External Multi-Function Outputs</i> .....	28
<i>Fast Control Port (Option FCP)</i> .....	28
<i>External Analog Inputs (Option AIQ)</i> .....	29
<i>SD Card (Option SD)</i> .....	29

**CONNECTORS ..... 30**  
    *Front Panel (Single Channel Model):..... 30*  
    *Rear Panel (Single Channel Model):..... 30*  
    *Front Panel (2U Multi-Channel Model):..... 31*  
    *Rear Panel (2U Multi-Channel Model):..... 31*

**ORDERING INFORMATION ..... 32**

**GENERAL CHARACTERISTICS ..... 32**  
    *Document History ..... 34*

**NOTES ..... 35**

## DEFINITIONS

The specifications in the following pages describe the warranted performance of the instrument for  $23 \pm 5$  °C after a 30-minute warm-up period (unless otherwise stated).

**Min/Max:** Parameter range that is guaranteed by product design, and/or production tested. Warranted performance specifications include guard-bands to account for the expected statistical performance distribution, measurement uncertainties, and changes in performance due to environmental conditions.

**Typical:** Expected mean values, not warranted performance.

## INTRODUCTION

### Ultra-Agile Vector Signal Generator

The Model 875 is an ultra-fast-switching vector-modulated signal generator series covering continuous frequency ranges from 10 MHz (100 kHz with option 100K) to 4, 6, 12, 20, or 40 GHz, respectively, with 0.001 Hz resolution, and 400 MHz RF modulation bandwidth.

The Model 875 is the corresponding multi-channel product series – up to 4 channels per device. This specification applies to single channel models as well as to the independent channels of multi-channel models.

A high performance internal I/Q modulator enables customized waveforms as modulation signals and supports a variety of modulation schemes including avionics modulation. The digital I/Q modulator ensures excellent carrier suppression and a very high image suppression. The standard Model 875 enables ultra-fast CW frequency sweeping, chirping, intra-pulse modulation, pulse shaping with very low phase noise. **Multi-channels models exhibit exceptionally high phase stability between channels synchronized by the same common reference.**

Among others, the following use cases are supported:

- Upload multiple formats of I/Q Data into the Model 875 Memory. A Model 875 GUI supports data formats from various vendors. The internal RAM can store up to 512 MS (32 bits per I/Q sample) of I/Q data. The Model 875 internal AWG can play selected sections of the RAM upon a user trigger.
- Use Model 875 to synthesize and play predefined digital modulation formats (option IVM)
- Use the analog I & Q inputs (option AIQ) with up to 50 MHz analog bandwidth.
- Use FCP interface (option FCP) to:
  - live stream digital I/Q data.
  - instantaneously switch between pre-loaded I/Q data segments.
  - control for ultra-fast frequency hopping (additionally, option UFS required).

All Models operate with an ultra-stable temperature compensated frequency reference (OCXO) that can be phaselocked to an external reference.

The compact device can be controlled by the touch display and a PC user interface.

This information is subject to change without notice.

This datasheet is valid for devices with serial number from xxx-xxx6x4xxx-xxxx and above.

# SPECIFICATIONS

## Frequency Parameters / Range

PARAMETER	MIN	TYPICAL	MAX	NOTE
Frequency Range	100 kHz			Option 100K
	10 MHz		4 GHz	875-04
			6 GHz	875-06
			12 GHz	875-12
			20 GHz	875-20
		40 GHz	875-40	
Settable Frequency Range <sup>1</sup>	100 kHz			Option 100K
	10 MHz		4.15 GHz	875-04
			6.6 GHz	875-06
			12 GHz	875-12
			20 GHz	875-20
		43.5 GHz	875-40	
Phase Adjustment Range	0 deg		360 deg	
Frequency Resolution		0.001 Hz		
Phase Resolution		0.01 deg		
Frequency & Amplitude Switching Time		500 $\mu$ s 1 $\mu$ s 2 $\mu$ s		875-04, 875-20, 875-40 875-04 Option UFS 875-20, 875-40 Option UFS

## Frequency Reference

PARAMETER	MIN	TYPICAL	MAX	NOTE
Internal Reference Frequency		100 MHz 10 MHz		Options LN / LN+
Initial Calibrated Accuracy			$\pm 10$ ppb	At 23 $\pm$ 3 °C
Temperature Stability 0 to 50 °C			$\pm 100$ ppb $\pm 20$ ppb	Options LN / LN+
Aging after 1st Year			1 ppm 30 ppb 20 ppb	Option LN Option LN+
Aging per Day			5 ppb 0.5 ppb	After 30 days operation Options LN / LN+
Warm-up Time		5 min		
<b>Reference Output</b>				
Output Frequency		10 MHz, 100 MHz		
Output Power		0 dBm 9 dBm		10 MHz 100 MHz
Output Impedance		50 $\Omega$		
<b>External Reference Input</b>				
Input Frequency Range	5 MHz	10 MHz	250 MHz	Option VREF
Frequency Resolution		1 MHz		Option VREF
Input Impedance		50 $\Omega$		
Input Power Level	-5 dBm	0 dBm	+10 dBm	
Lock Range	$\pm 1.5$ ppm			

<sup>1</sup> Performance above frequency range not guaranteed

## Level Performance

PARAMETER	MIN	TYPICAL	MAX	NOTE
<b>Output Power Level 875</b>				
100 kHz to 100 MHz	-20 dBm		+15 dBm	Option 100K
<b>Output Power Level 875-04</b>				
10 to 100 MHz	-20 dBm -55 dBm		+10 dBm +8 dBm	Option PE4

	-90 dBm -120 dBm		+10 dBm +10 dBm	Option PE2 Option PE
0.1 to 4 GHz	-20 dBm -55 dBm -90 dBm -120 dBm		+18 dBm +17 dBm +17 dBm +17 dBm	Option PE4 Option PE Option PE2
<b>Output Power Level 875-06</b>				
10 to 100 MHz	-20 dBm -55 dBm -90 dBm -120 dBm		+10 dBm +8 dBm +10 dBm +10 dBm	Option PE4 Option PE Option PE2
0.1 to 6 GHz	-20 dBm -55 dBm -90 dBm -120 dBm		+15 dBm +15 dBm +15 dBm +15 dBm	Option PE4 Option PE Option PE2
<b>Output Power Level 875-12</b>				
10 to 100 MHz	-20 dBm -55 dBm -90 dBm -120 dBm		+10 dBm +8 dBm +10 dBm +10 dBm	Option PE4 Option PE Option PE2
<b>Output Power Level 875-20</b>				
10 to 100 MHz	-20 dBm -90 dBm -120 dBm		+10 dBm +10 dBm +10 dBm	Option PE Option PE2
0.1 to 20 GHz	-20 dBm -90 dBm -120 dBm		+17 dBm +16 dBm +16 dBm	Option PE Option PE2
<b>Output Power Level 875-40</b>				
10 to 100 MHz	-20 dBm -90 dBm -120 dBm		+10 dBm +10 dBm +10 dBm	Option PE Option PE2
0.1 to 20 GHz	-20 dBm -90 dBm -120 dBm		+17 dBm +16 dBm +16 dBm	Option PE Option PE2
20 to 26 GHz	-20 dBm -90 dBm -120 dBm		+16 dBm +15 dBm +14 dBm	Option PE Option PE2
26 to 40 GHz	-20 dBm -90 dBm -120 dBm		+15 dBm +13 dBm +12 dBm	Option PE Option PE2
<b>Power Resolution</b>		0.01 dB		

**Figure 1: Maximum Output Power 875-04**

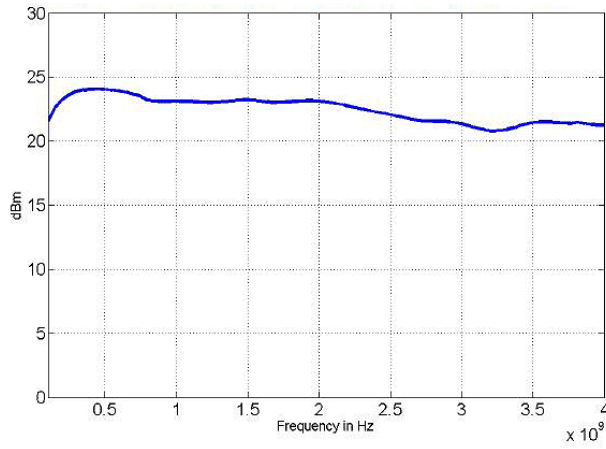

**Figure 2: Maximum Output Power 875-06**

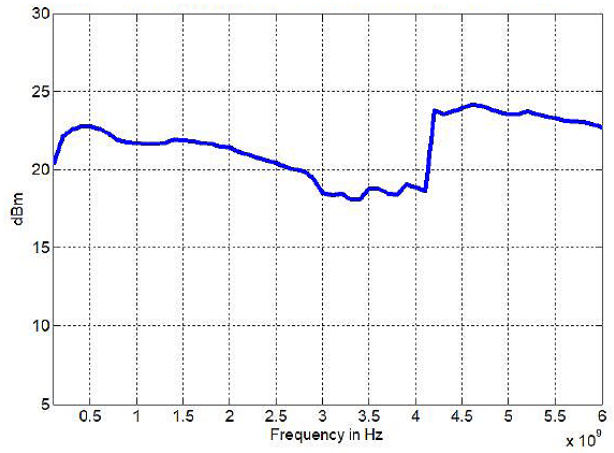

**Figure 3: Maximum Output Power 875-20/40**

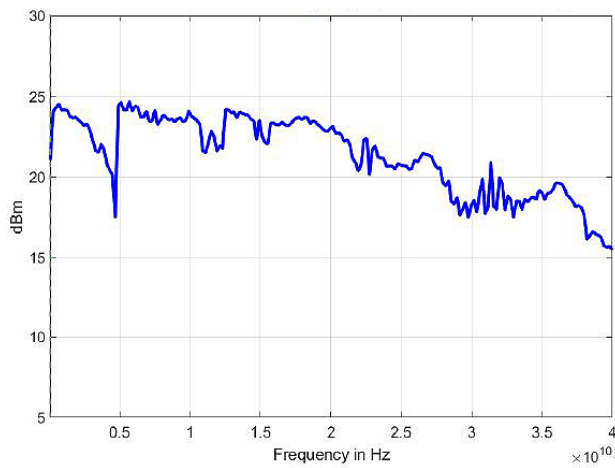

**Power Level Uncertainty**

PARAMETER	MIN	TYPICAL	MAX	NOTE
< 4 GHz		0.25 dB	0.7 dB	> -20 dBm
4 to 6 GHz		0.3 dB	1.0 dB	
6 to 20 GHz		0.3 dB	1.3 dB	
20 to 40 GHz			1.5 dB	Pmin to -20 dBm
< 4 GHz		0.3 dB	0.8 dB	
4 to 6 GHz		0.35 dB	1.2 dB	
6 to 20 GHz		0.4 dB	1.4 dB	
20 to 40 GHz		0.5 dB	1.6 dB	

**Figure 4: Power Level Accuracy 875-12**

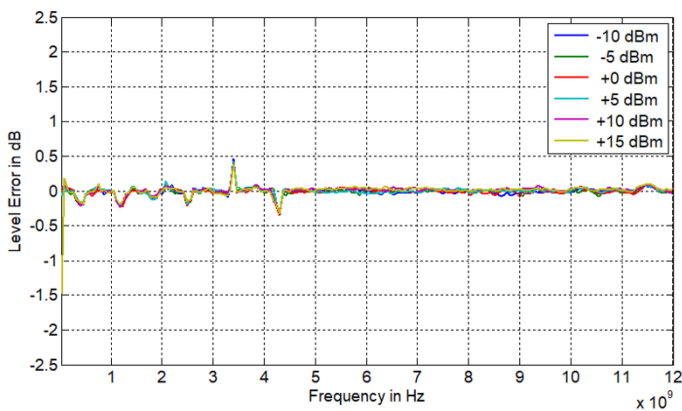

**Figure 5: Power Level Accuracy 875-12**

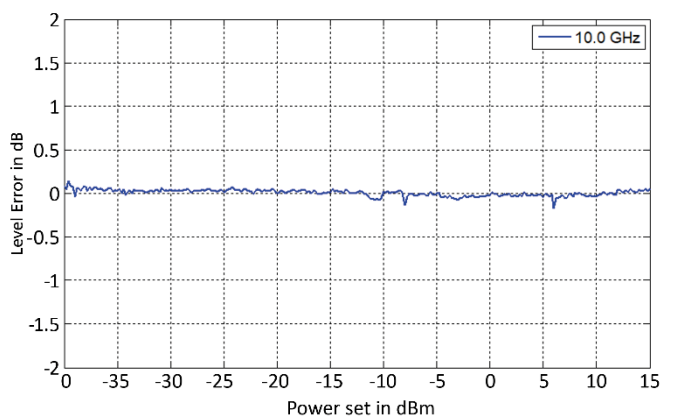

**Figure 6: Power Level Accuracy 875-40**

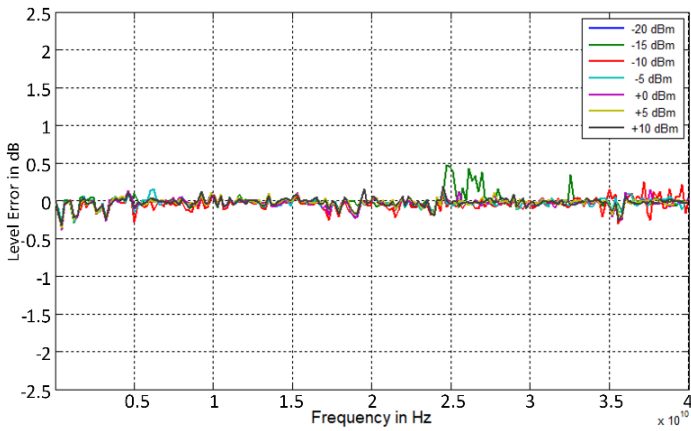

**Figure 7: Power Level Accuracy 875-20**

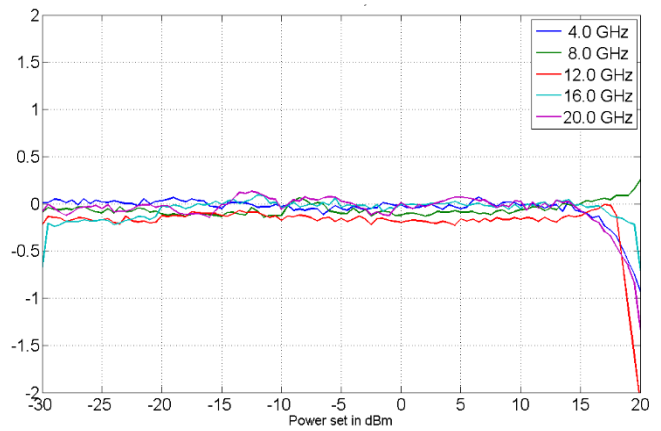

**Reverse Power Protection and VSWR**

PARAMETER	MIN	TYPICAL	MAX	NOTE
DC Voltage			±10 V	
RF Power			+26 dBm	
Output Impedance		50 Ω		
VSWR		1.8		See Figure 14

**Figure 8: Typical VSWR 875-04**

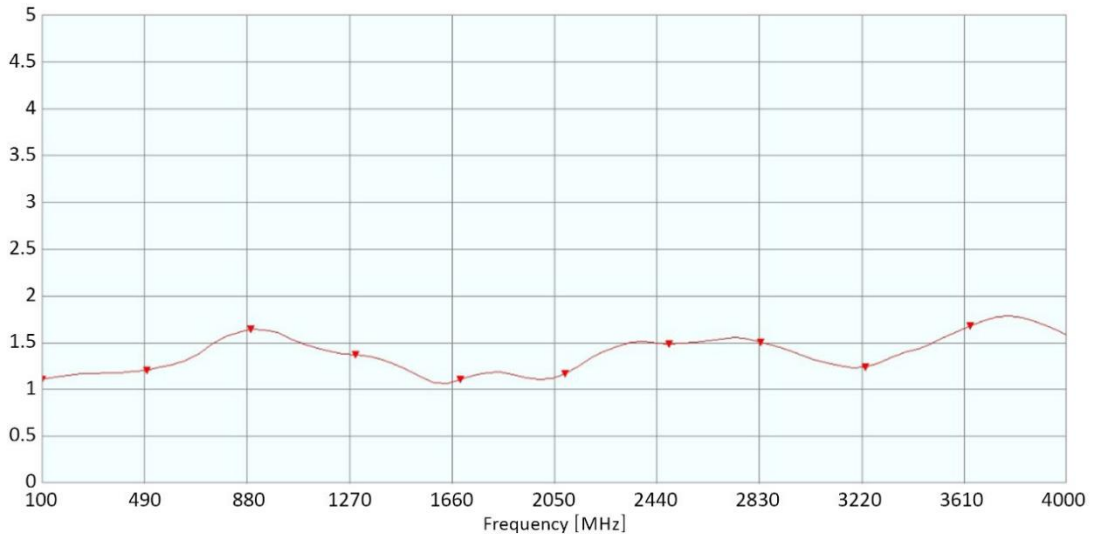

**Figure 9: Typical VSWR 875-12 & 875-20**

*\*no image yet\**

**Phase Noise**

PARAMETER	MIN	TYPICAL	MAX	NOTE
SSB Phase Noise at 1 GHz, +10 dBm				See Figures 1, 2
At 10 Hz from Carrier		-87 dBc/Hz -98 dBc/Hz	-84 dBc/Hz	Option LN
At 1 kHz from Carrier		-130 dBc/Hz		
At 20 kHz from Carrier		-145 dBc/Hz		

At 100 kHz from Carrier		-150 dBc/Hz		
<b>SSB Phase Noise at 4 GHz, +10 dBm</b>				See Figures 1, 2
At 10 Hz from Carrier		-74 dBc/Hz	-74 dBc/Hz	Option LN
		-90 dBc/Hz		
At 1 kHz from Carrier		-121 dBc/Hz		
At 20 kHz from Carrier		-133 dBc/Hz		
At 100 kHz from Carrier		-138 dBc/Hz		
<b>SSB Phase Noise at 10 GHz, +10 dBm</b>				See Figures 1, 2
<b>875-20 &amp; 875-40</b>				
At 10 Hz from Carrier		-66 dBc/Hz	-65 dBc/Hz	Option LN
		-76 dBc/Hz		
At 1 kHz from Carrier		-104 dBc/Hz		
At 20 kHz from Carrier		-115 dBc/Hz		
At 10 MHz from Carrier		-118 dBc/Hz		
<b>SSB Phase Noise at 20 GHz, +10 dBm</b>				
<b>875-20 &amp; 875-40</b>				
At 10 Hz from Carrier		-60 dBc/Hz	-59 dBc/Hz	Option LN
		-70 dBc/Hz		
At 1 kHz from Carrier		-104 dBc/Hz		
At 20 kHz from Carrier		-115 dBc/Hz		
At 10 MHz from Carrier		-118 dBc/Hz		

**Figure 10: SSB Phase Noise Performance, 875-20/40, CW without option LN, Pout = +10 dBm**

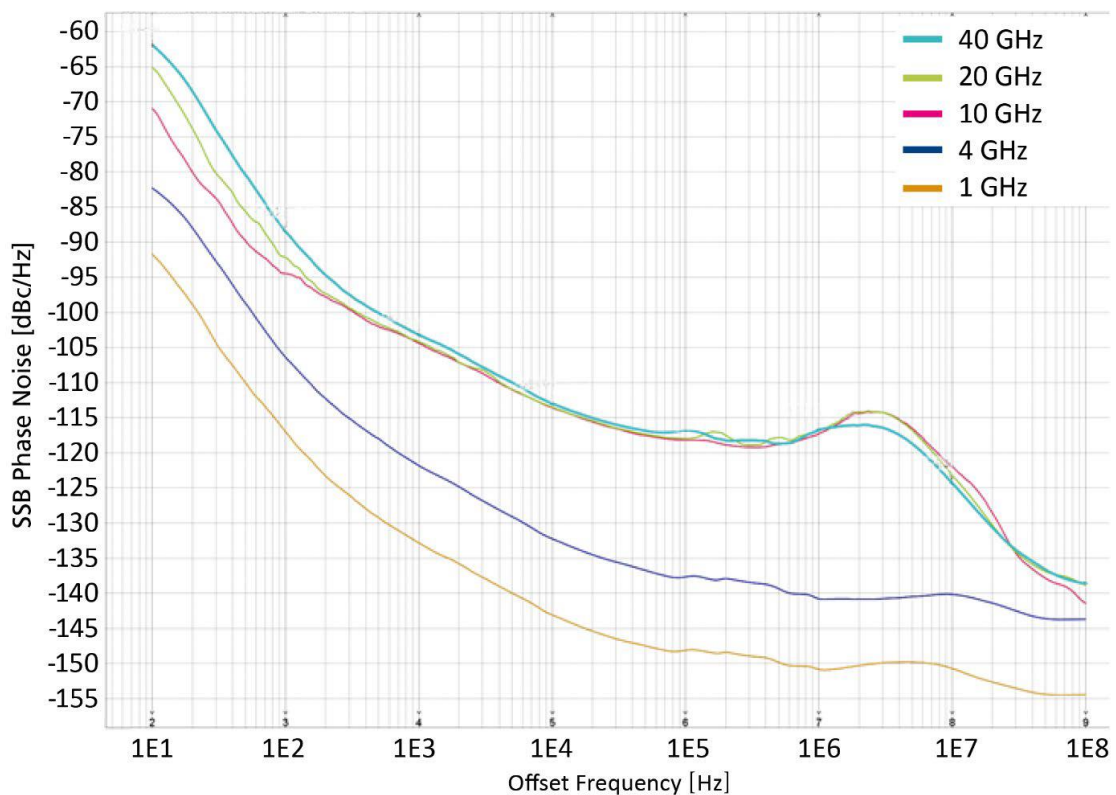

Figure 11: SSB Phase Noise Performance, 875-XX, low frequency CW without option LN, Pout = +10 dBm

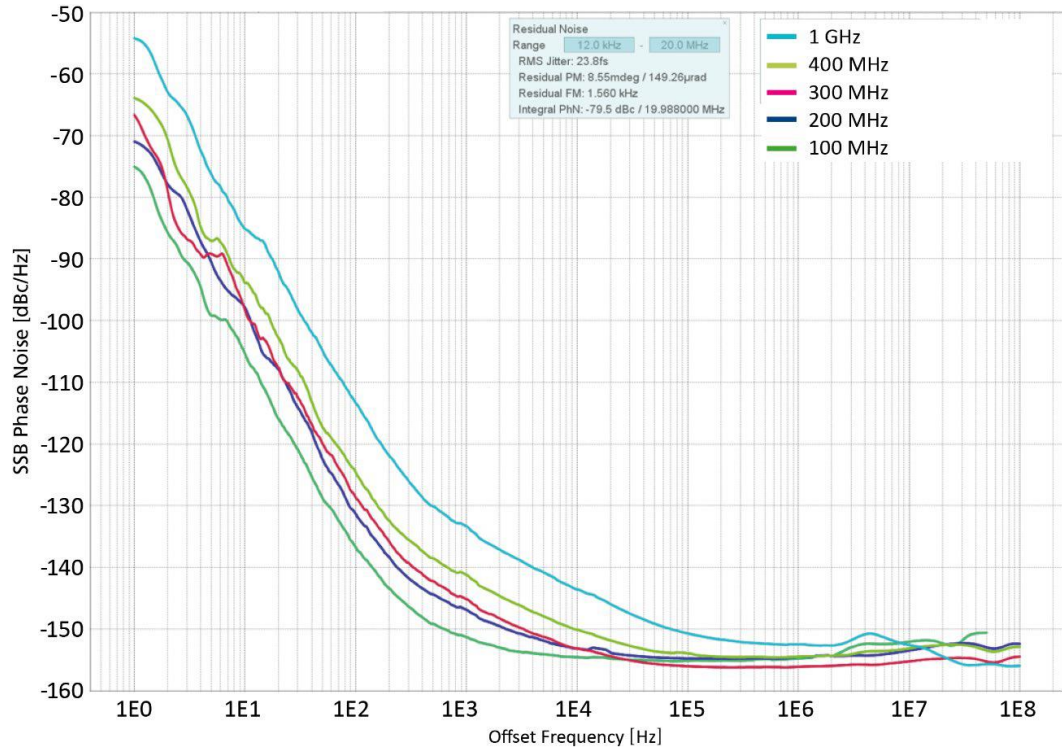
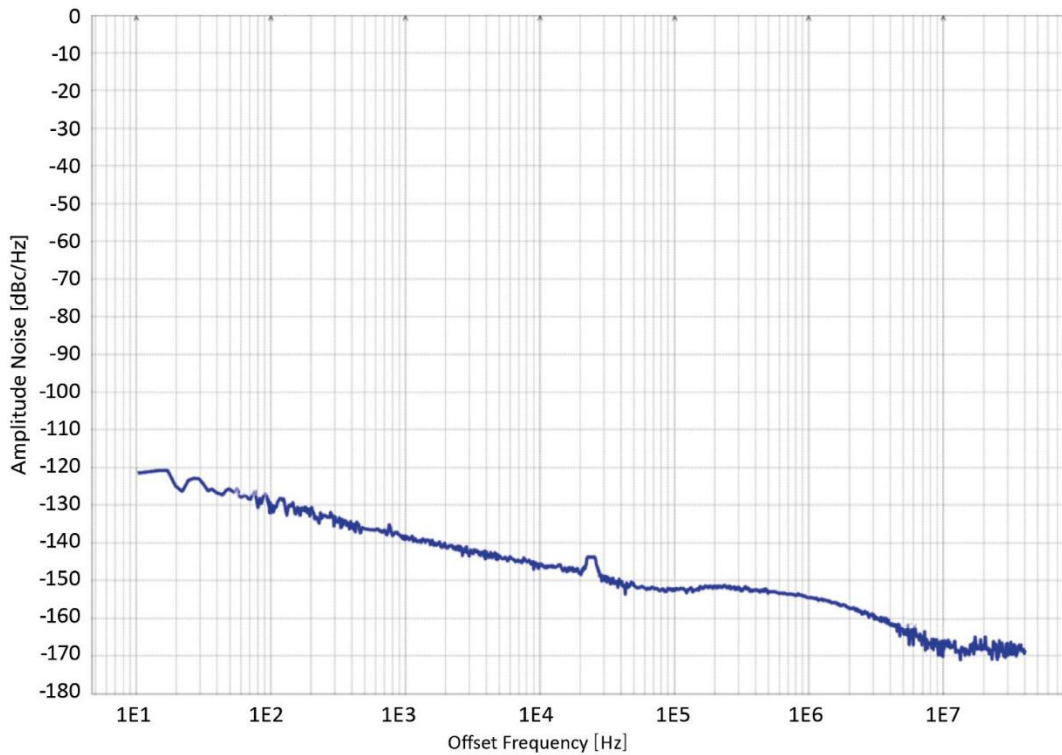

Figure 12: Amplitude Noise, 2 GHz, Pout = +10 dBm



PARAMETER	MIN	TYPICAL	MAX	NOTE
<b>Harmonics @ 0 dBm 875-04</b>				
0.01 to 2 GHz		-55 dBc	-48 dBc	
2 to 4 GHz		-45 dBc	-40 dBc	

<b>Harmonics @ 0 dBm 875-06</b> 0.01 to 4 GHz 4 to 6 GHz		-45 dBc -35 dBc	-40 dBc -30 dBc	
<b>Harmonics @ 0 dBm 875-12</b> 0.01 to 4 GHz 4 to 7 GHz 7 to 12 GHz		-45 dBc -35 dBc -55 dBc	-40 dBc -30 dBc -50 dBc	
<b>Harmonics @ 0 dBm 875-20</b> 0.01 to 4.5 GHz 4.5 to 10.5 GHz >10.5 GHz		-50 dBc -40 dBc -55 dBc	-40 dBc -35 dBc -48 dBc	
<b>Harmonics @ dBm 875-40</b> 0.01 to 4.5 GHz 4.5 to 20 GHz >20 GHz		-50 dBc -35 dBc -35 dBc	-45 dBc -30 dBc -30 dBc	
<b>Non-Harmonic Spurious</b> (at 0 dBm Output, > 10 kHz Offset)		-90 dBc -80 dBc -80 dBc -70 dBc -60 dBc -55 dBc	-75 dBc -70 dBc -55 dBc -50 dBc -50 dBc -45 dBc	< 1.2 GHz 1.2 to 2.5 GHz 2.5 to 4 GHz 4 to 12 GHz 12 to 20 GHz > 20 GHz

**Figure 13: 875-06 – Harmonic Performance at Pout = 0 dBm**

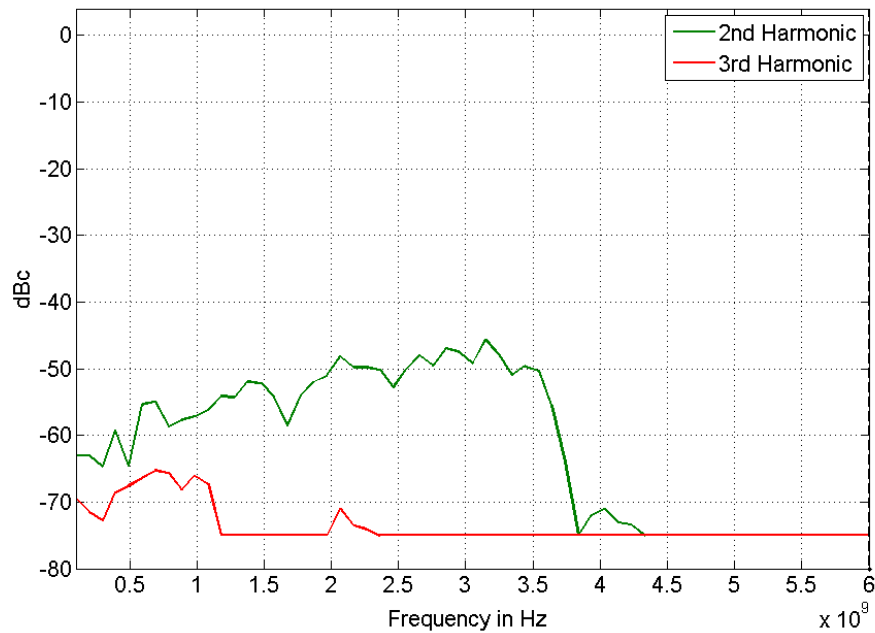
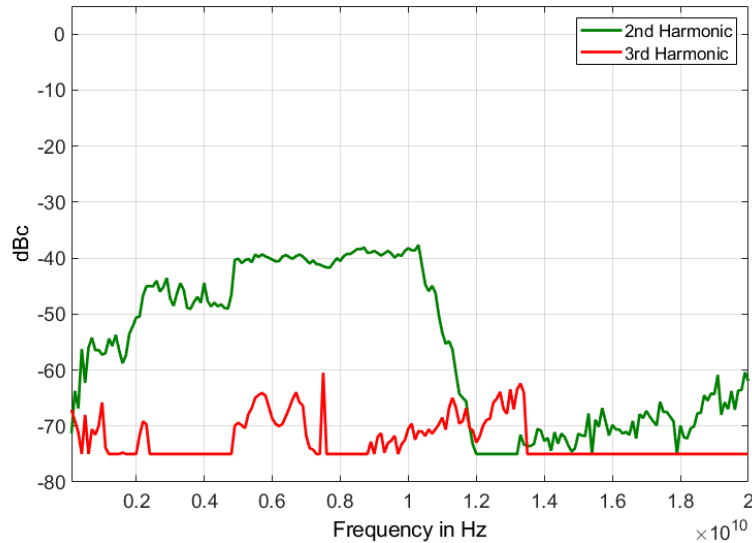

Figure 14: 875-20 – Harmonic Performance at Pout = 0 dBm



## Sweeping Capability

PARAMETER	MIN	TYPICAL	MAX	NOTE
<b>Sweep Type</b>	Digital sweep in discrete steps			
Automatic Level Control (ALC) Mode	OFF			
Power Level Uncertainty		0.5 dB TBD	1 dB TBD	875-04 875-06/12/20/40
Frequency & Amplitude Switching Transient Time (can be blanked during “Delay Time”)		500 μs 1 μs 2 μs		875-04 Option UFS 875-20, 875-40 Option UFS
<b>Sweep Spacing</b>	Linear			
<b>Sweep Shape</b>	Sawtooth			
<b>Sweep Parameters</b>	Frequency, Power			
Sweep Range	Full specified range -20 to +15 dBm			Frequency sweep Power sweep, 875-04
Step Size Setting Resolution	0.001 Hz 0.01 dB			Frequency Sweep Power Sweep
Dwell Time Setting Range	500 μs 800 ns TBD		34.35 s 34.35 s 34.35 s	875-04 Option UFS 875-20, 875-40 Option UFS
Delay (off) Time Setting Range	200 ns 200 ns		34.35 s 34.35 s	875-04 875-20, 875-40
Dwell/Delay Time Resolution	8 ns			
<b>Sweep Count</b>	Infinite, 1 to 1 M			
<b>Sweep Trigger</b>				
Trigger Type	Normal (full sweep), Point (one step)			Check with BNC support
Trigger Parameters	See Chapter “Trigger Capability”			
Retrigger Setup Time	200 ns			
External Trigger Event to RF Output Delay	TBD TBD			875-04, Option UFS 875-20, 875-40, Option UFS

## Phase Coherence

### Phase-Coherent Modes

MODE	DESCRIPTION	REMARKS
Phase coherent switching <sup>2</sup>  (Multi-channels mode)	Phase coherent switching guarantees deterministic and reproducible phase relationships between multiple individual channels across multiple individual units.	Option PHS

Phase coherent switching <sup>2</sup> (Multi-device mode)	The Phase-coherent switching model also enables synchronous playback of IQ waveforms on multiple channels and multiple devices	Options SYNC+PHS
Phase Memory	With phase memory the RF output phase behave as if switching between individual, continuously running RF sources	Option PHS
Phase calibratable mode	Different combinations of phase correction and phase calibratable mode are available: <ul style="list-style-type: none"> <li>Phase correction off, phase calibratable mode off: This is the default operation mode. Channel-to-channel relative phases are stable and repeatable, but not zero and vary over power and frequency.</li> <li>Phase correction off, phase calibratable mode on: This mode enables linear relative phase variation over frequency and static phase over power. Channel-to-channel relative phases are stable and repeatable, but not zero.</li> <li>Phase correction on, phase calibratable mode on: Correction values are interpolated between points. This enables true zero phase offset between channels over any frequency / power range (up to a device's full power and frequency range).</li> </ul>	Option PCM

**Figure 15: Phase-Coherent Switching**

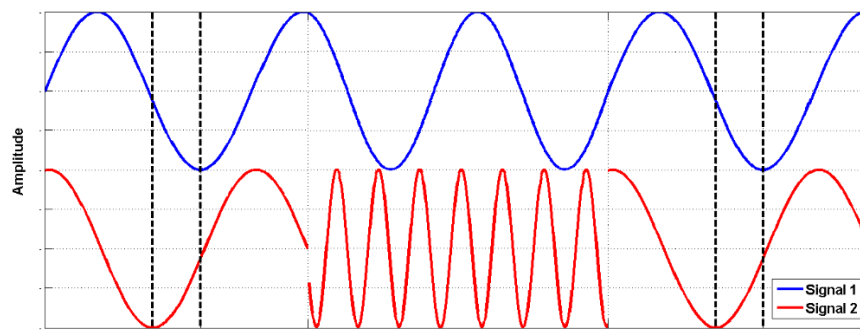

The relative phase between channels 1 and 2 (signal 1 and 2) remains the same after channel 2 temporarily switched to a different frequency. The frequency switching itself is phase discontinuous because the original phase is restored.

**Figure 16: Phase Memory**

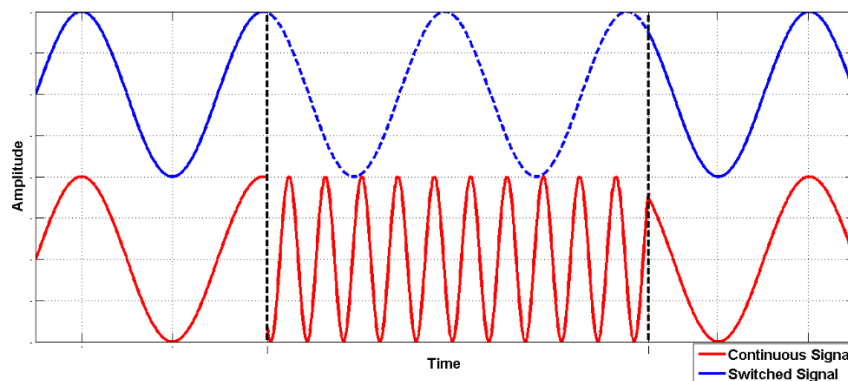

The signal returns to the same absolute phase when returning to the previous frequency and amplitude setting.

<sup>2</sup> Limitations. As the synthesized signal undergoes further routing and signal conditioning, like filtering and amplitude control, it is subject to electrical delays before reaching the RF output. Those delays vary with RF amplitude and frequency but are otherwise stable. That means that the relative phase between channels will not be zero, but still deterministic and reproducible. For any fixed combination of frequency and amplitude settings, the resulting relative phase between channels will always be the same, even over power cycles.

### Multi-Channel Performance

PARAMETER	MIN	TYPICAL	MAX	NOTE
Isolation between channels	> 90 dB			
Relative Phase Stability	TBD			
<b>Additional Features</b>				
Trigger Source	Synchronous (initiate and trigger multiple channels)			
Additional Delay to Asynchronous Characterizations	1 $\mu$ s +/- 100 ns			
Channel to Channel Jitter	+/- 10 ps typ.			

Figure 17: Phase coherence performance at 38 GHz

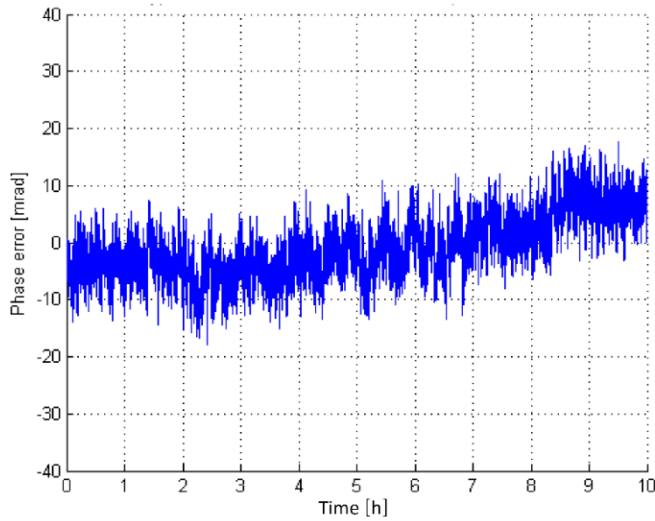
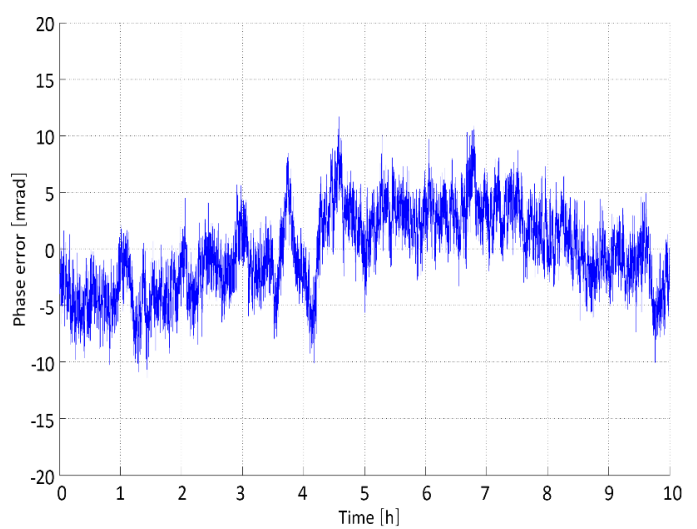

Figure 18: Phase coherence performance at 15 GHz



### Multi-Device Performance (Option SYNC)

PARAMETER	MIN	TYPICAL	MAX	NOTE
Multi-Device Synchronization	TBD			
Relative Phase Stability	TBD			

Figure 19: 875 typical domain channel-to-channel phase error at CH1 @0.5 GHz mixed with Ch2 @2.5 GHz VS 2 GHz from other device

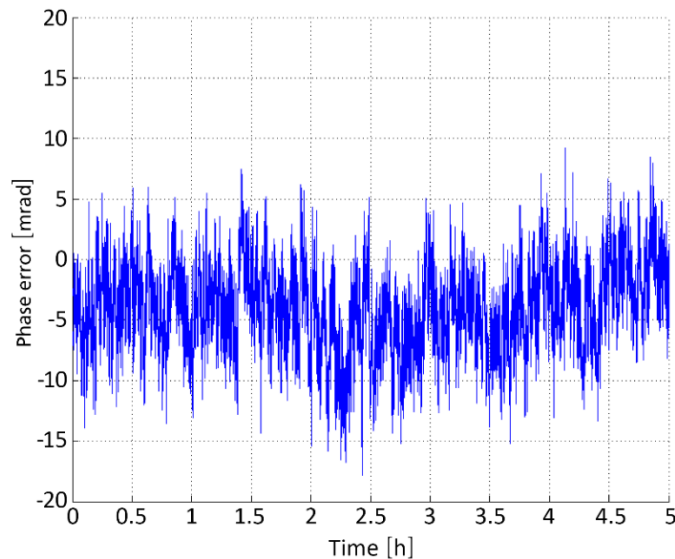

**Figure 20: Connections for multi device synchronization: The reference clock uses SMA connectors. Connectors and cable must support at least 6 GHz bandwidth. The synchronization signals A, B, C use SMB connectors. Connectors and cables must support at least 3 GHz bandwidth.**

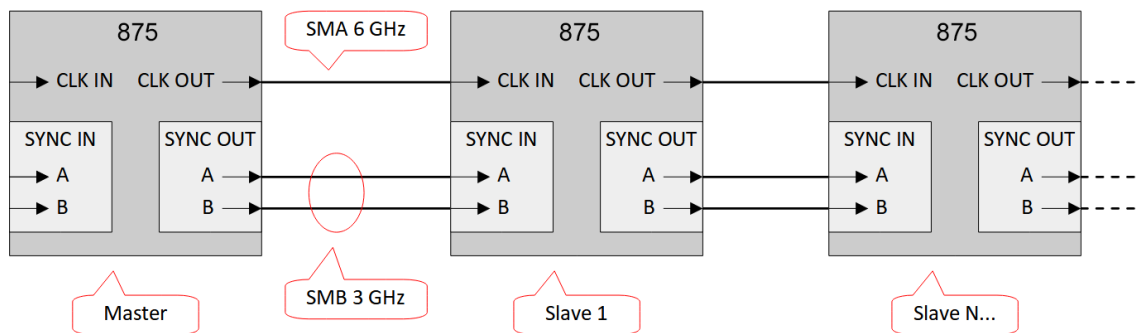

## Analog Modulation (Option MOD)

### Pulse Modulation

PARAMETER	MIN	TYPICAL	MAX	NOTE
<b>Pulse Modulation</b>				
Modulation Source	Internal pulse generator, external			
Modulator	RF, BB (baseband)			
Pulse Rise/Fall Time		5 ns		10% / 90% of amplitude
On/Off Ratio	90 dB 40 dB Tbd dB	95 dB 45 dB Tbd dB		BB pulse modulator <4 GHz RF pulse modulator >4 GHz RF pulse modulator
Pulse Overshoot			1 dB	
Video Feedthrough		-70 dB -50 dB		0 dBm, PRF 500 kHz, 50% duty cycle, BB pulse modulator 1 GHz 20 GHz
Polarity / Video Polarity	Normal, inverted			Independently selectable
External Pulse Input to Video Output Delay		20 ns		
Video Output to RF Output Delay		5 ns 400 ns		RF Modulator BB modulator
External Trigger to Video Output Delay		TBD		
Pulse Jitter		<10 ps +/-8 ns	< 1 ps	Internal External, RF pulse modulator External, BB pulse modulator
<b>Internal Pulse Generator</b>				
Pulse Mode	Single pulse			
Pulse Period Setting Range	2* min pulse width setting		10 s	
Pulse Period Setting Resolution	8 ns			
Pulse Width Setting Range	96 ns 8 ns		10 s	Option UFS
Pulse Width Setting Resolution	8 ns			
Pulse Width Accuracy	Same as time base			

**Figure 21: Pulsed Chirp (10  $\mu$ s, 400 MHz Bandwidth)**

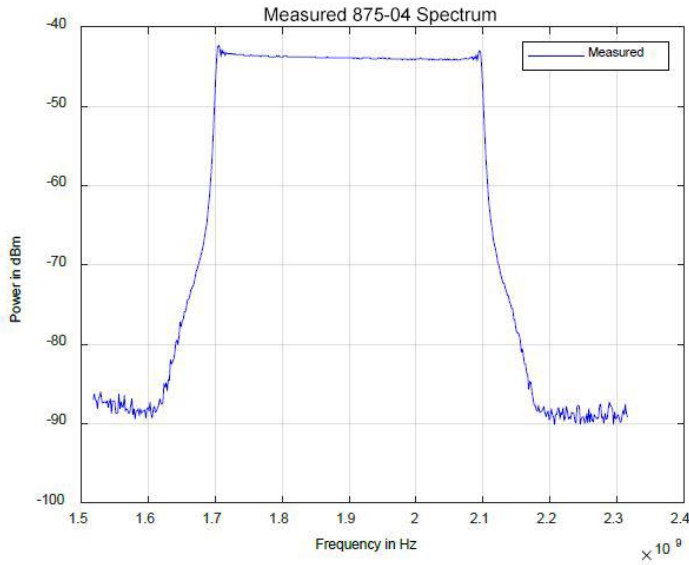

**Figure 22: Pulse Modulation (10 MHz Rate, 10 ns Pulse Width)**

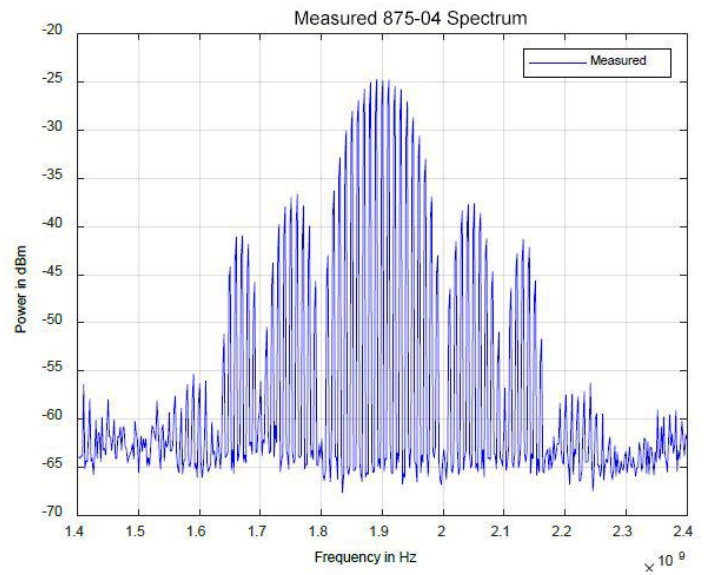

**Figure 23: Pulse modulation 16 ns at 10 GHz**

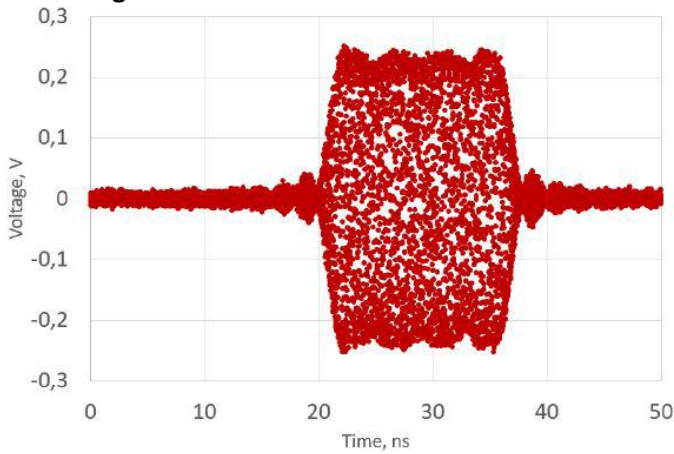

**Figure 24: Pulse modulation 16 ns at 40 GHz**

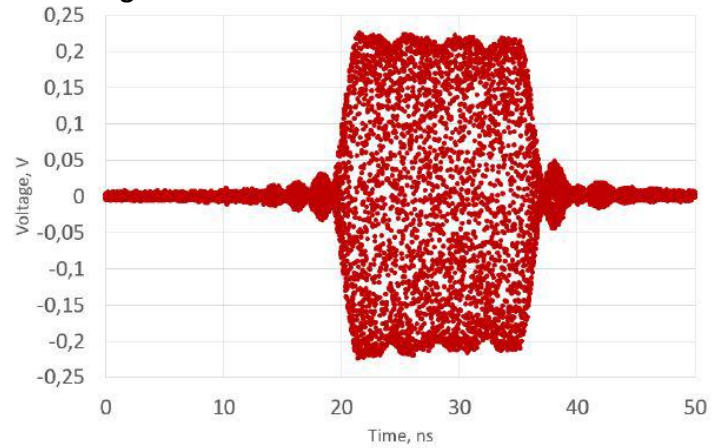

**Amplitude Modulation**

PARAMETER	MIN	TYPICAL	MAX	NOTE
<b>Amplitude Modulation</b>				
Modulation Source		Internal External		Option AIQ
Modulation Depth	0%		99.9%	Output is clipped at max power level
Deviation Accuracy		0.1%	1%	1 kHz rate, 80% depth
Deviation Resolution		0.1%		
Distortion (THD)			1%	
Modulation Frequency Range	0.1 Hz		100 MHz	
Modulation Waveforms		Sine		

**Figure 25: Amplitude Modulation (1 kHz Rate, 80% Depth)**

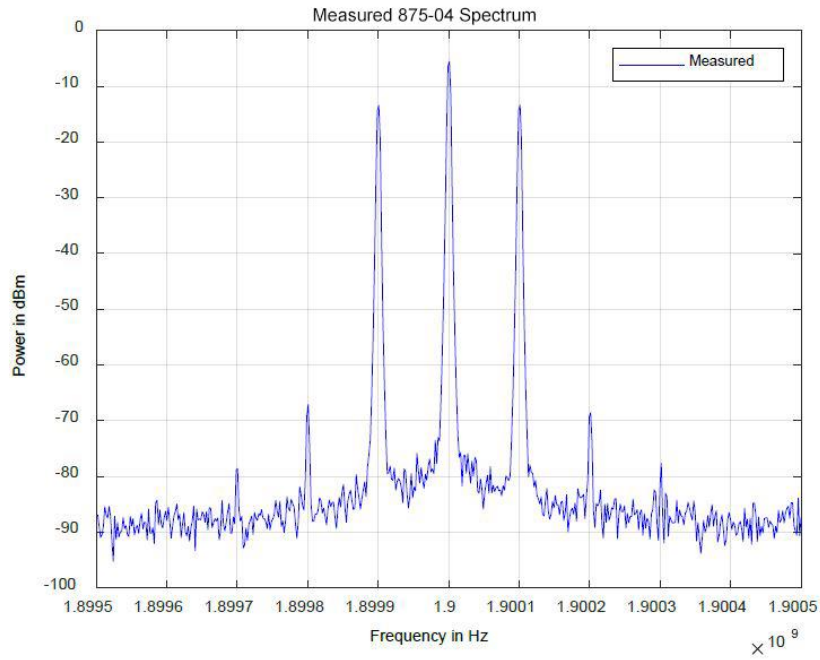

**Frequency Modulation**

PARAMETER	MIN	TYPICAL	MAX	NOTE
<b>Frequency Modulation</b>				
Modulation Source		Internal External		Option AIQ
Maximum Frequency Deviation (peak)		200 MHz		Output is clipped at max power level
Deviation Accuracy		0.5%	1%	
Distortion (THD)		< 1%		
Modulation Frequency Range	0.1 Hz		100 MHz	
Modulation Waveforms		Sine		

**Figure 26: Wideband FM (1 MHz Rate, 200 MHz Deviation)**

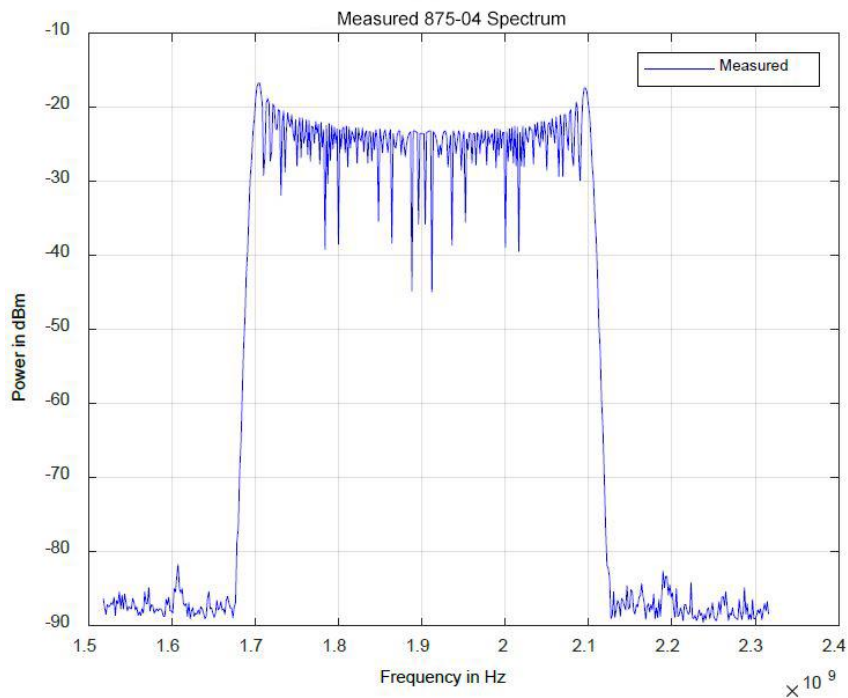

## Phase Modulation

PARAMETER	MIN	TYPICAL	MAX	NOTE
<b>Phase Modulation</b>				
Modulation Source		Internal External		Option AIQ
Phase Deviation (peak)	0		100 rad	
Deviation Accuracy		0.5%	1%	
Modulation Frequency Range	0.1 Hz		100 MHz	
Modulation Waveforms		Sine		
Distortion (THD)		< 1%		1 kHz rate & N x rad deviation

## Pulse Descriptor Word (Option PDW)

The PDW is an operating mode of the 875 which takes control of the RF output. Other 875 features cannot be used simultaneously unless their settings are available as PDW parameters. The PDW feature supports several methods for uploading parameters to the device, including PDW list files in .csv format and streaming through FCP.

PARAMETER	MIN	TYPICAL	MAX	NOTE
<b>PDW Format</b>				
PDW Mode		List Stream		See App Note AN6008 for PDW details  Option FCP
PDW Time Mode		Relative, absolute		
Controllable Parameters		Start time, pulse width, frequency, power, phase, waveform segment ID		
Parameter Range		Full specified range -20 to +15 dBm 8 ns to 208 d 8 ns to 208 d		RF Frequency / RF Phase RF Power Start Time Pulse Width
Parameter Setting Resolution		1/29 Hz 1/27 dB 0.0055 deg 8 ns		RF Frequency RF Power RF Phase Start Time / Pulse Width
Automatic Level Control (ALC) Mode		OFF		
Power Level Uncertainty		0.5 dB <i>TBD</i>	1 dB <i>TBD</i>	875-04 875-20, 875-40
<b>PDW Timing</b>				
Switching Time (transient)		500 $\mu$ s <i>TBD</i> ( $\approx$ 20 $\mu$ s) 2 $\mu$ s 3.2 $\mu$ s		See AN6008 for timing details  875-06/12/20/40 Option UFS 875-04 Option UFS & Option PHS 875-04 Option UFS
Pulse Width	32 ns 8 ns			Option UFS
Play Time			208 d	Absolute Time Mode
Simulation Trigger Setup Time		32 ns		
Trigger Parameters		See chapter "trigger capability"		
PDW Buffer Size	1 PDW		1024 PDW	For both PDW modes
PDW List Count		Infinite, 1 to 65 M		

## Mode Overview

PDW Mode	Input Interface	PDW upload	Device Storage	Simulation
List	875 GUI/ SCPI commands	Before simulation starts	PDW Memory	All PDWs in List, optionally repeat list
Stream	FCP / SCPI commands	Before and during Simulation	PDW Buffer (FIFO)	PDWs in order of upload, only once.

PARAMETER	MIN	TYPICAL	MAX	NOTE
RF modulation bandwidth		400 MHz		
I/Q Frequency Response over full 400 MHz		±1.0 dB	±1.5 dB	< 6 GHz
I/Q Bandwidth		±1.5 dB	±2.5 dB	6 to 20 GHz
		±2.0 dB	±3.5 dB	20 to 40 GHz
Carrier Leakage		-90 dBc	-70 dBc	
Image Sideband Rejection	65 dBc	85 dBc		

**Figure 27: I/Q Relative Response (measured) 875-04**

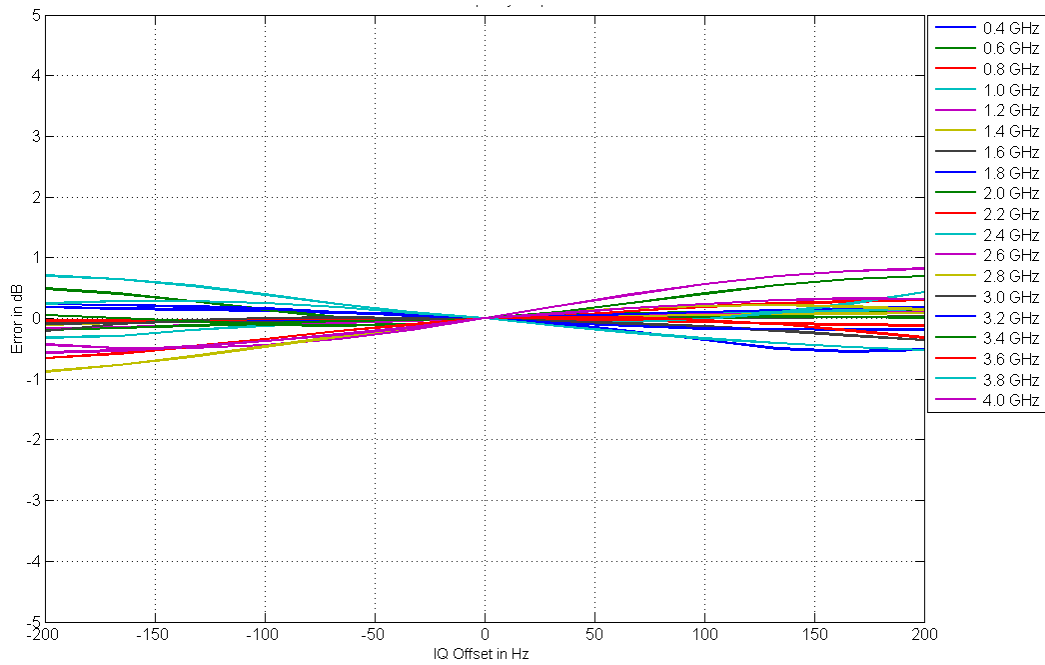

**Figure 28: I/Q Relative Response (measured) 875-20**

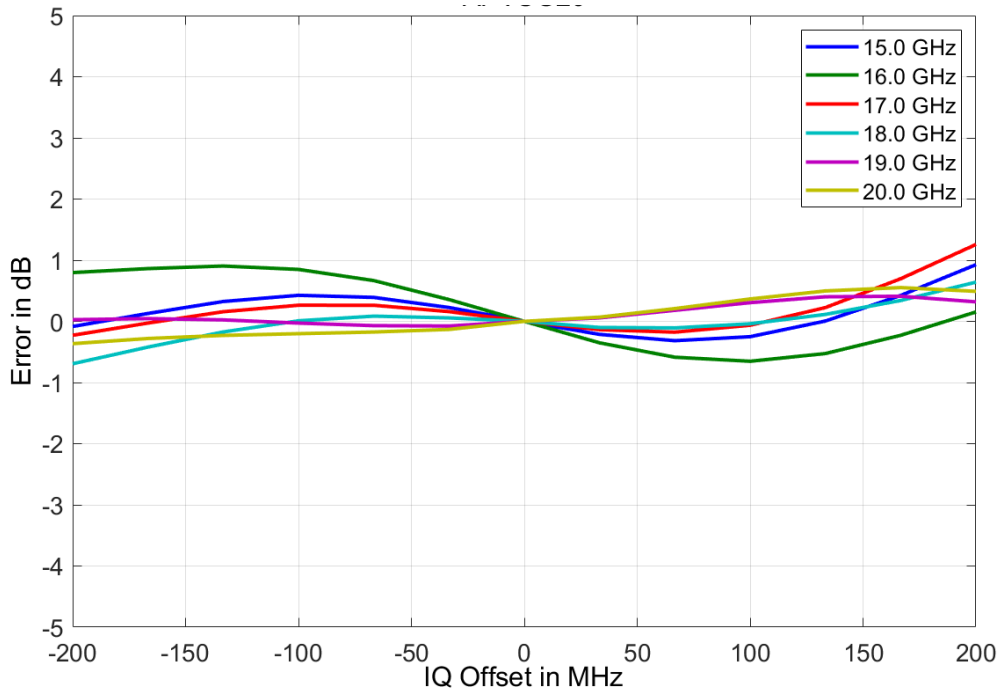
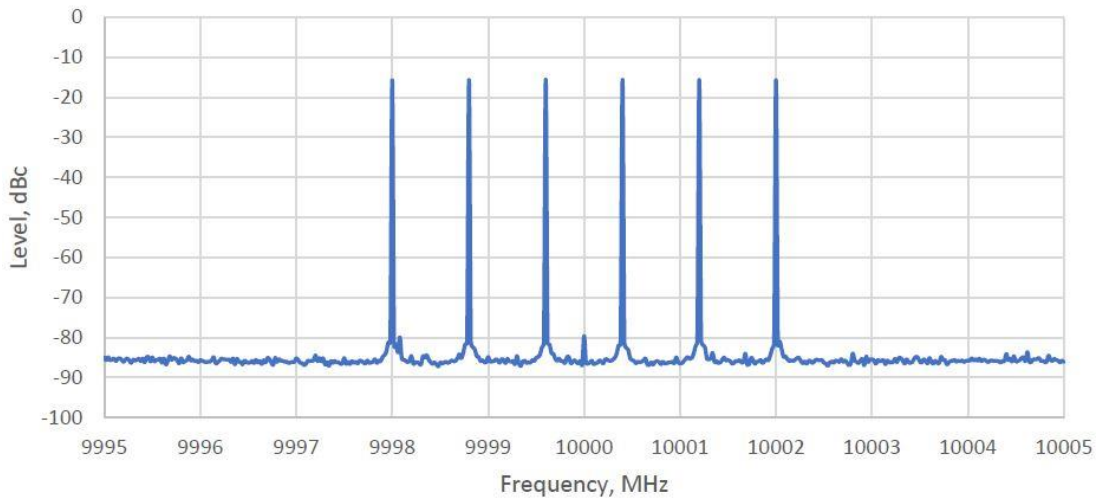

Figure 29: Carrier suppression -80 dBc for 0 dBm 6-tone signal at 10 GHz carrier



### Internal I/Q Baseband Generator

PARAMETER	MIN	TYPICAL	MAX	NOTE
Sample resolution	16 bits			
Clock Source	Internal			
Sample rate	10 Hz		500 MHz	
Sample Rate Resolution	1 Hz			
Waveform length, number of samples	96* 246*		512 M 334 M	Marker signals active
<b>Segment Mode</b>				
Number of segments	1		65 k	
Segment Changeover	Seamless, immediate			
Trigger Modes	Same segment, next segment, addressed segment			
Sequencer Play List Length	1		2048	
Sequence Segment Repetitions	1		10 M	
Changeover Time		2 $\mu$ s		500 MHz sample rate, after trigger event received, immediate segment changeover
<b>Arbitrary Trigger</b>				
Trigger Type	Normal, Next segment, next sequence			Check with BNC support
Trigger Parameters	See Chapter "Trigger Capability"			
External Trigger Event to RF Output Delay	0.5 $\mu$ s +/-100 ns			500 MHz sample rate
<b>Marker Signals</b>	Markers are defined during the waveform generation process.			
Number of Markers		4		
Type		Waveform		
Marker Delay Setting Range		Tbd		
Marker Delay Setting Resolution		Tbd		
Marker duration minimum value		1 sample 4 samples		Sample rate $\leq$ 125 MHz Sample rate $>$ 125 MHz
Marker Duration Variation			+/- 1 sample +/- 8 ns	Sample rate $<$ 125 MHz Sample rate $\geq$ 125 MHz
Marker Jitter			+/- 1 sample +/- 8 ns	Sample rate $<$ 125 MHz Sample rate $\geq$ 125 MHz
Marker Polarity	Normal, inverted			
Marker Output to RF Output Delay		tbd		

\*Shorter Waveforms will be automatically extended by cyclically repeating the waveform.

### Internal Vector Modulation (Option IVM)

PARAMETER	MIN	TYPICAL	MAX	NOTE
Modulation Schemes	8QAM, 16QAM, 32QAM, 64QAM, 128QAM, 256QAM, 512QAM, 1024QAM, 2048QAM, 4096QAM			
Symbol Rate	10 S/s		200 MS/s	

Filter Type	cosine, root cosine, gaussian, rectangular, dirac, rectangular asymmetric		
Filter Parameter Range	0.05 0.05		1 2.5
Data Source	PRBS generator, user data list, external real-time data		
Data Lists	8 bits		256 Mbits
	Option, check with BNC support		

**Figure 30: 256QAM 10 MS/s**

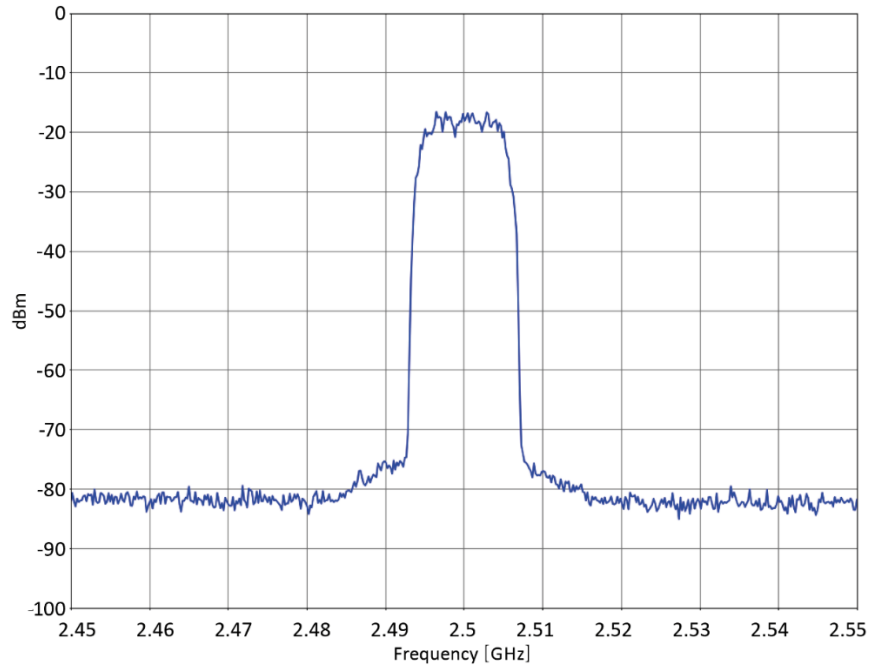

**Figure 31: 16QAM 250 MS/s**

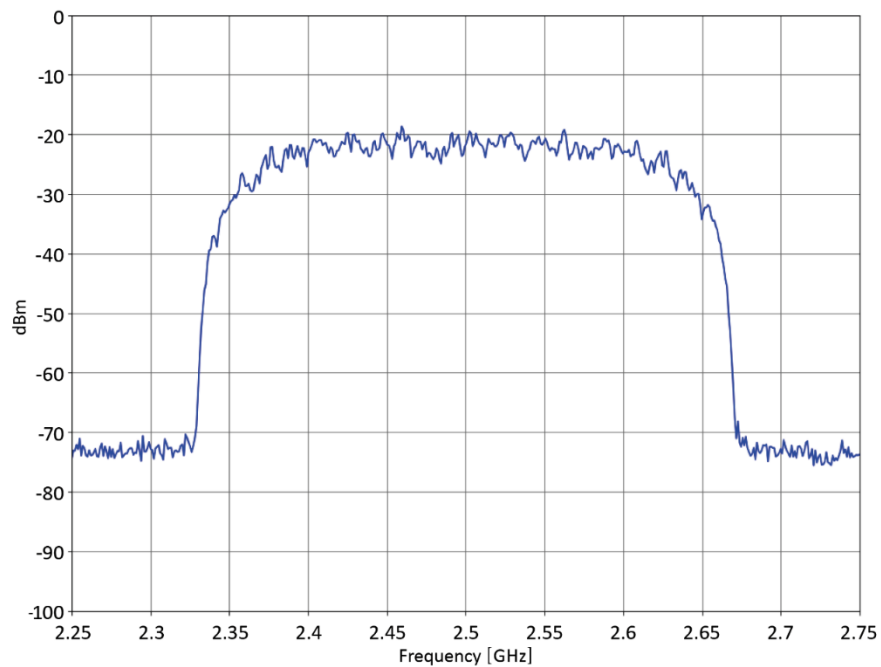

**Figure 32: EMV vs. Output Power, 16QAM, 10 MS/s, 2.5 GHz**

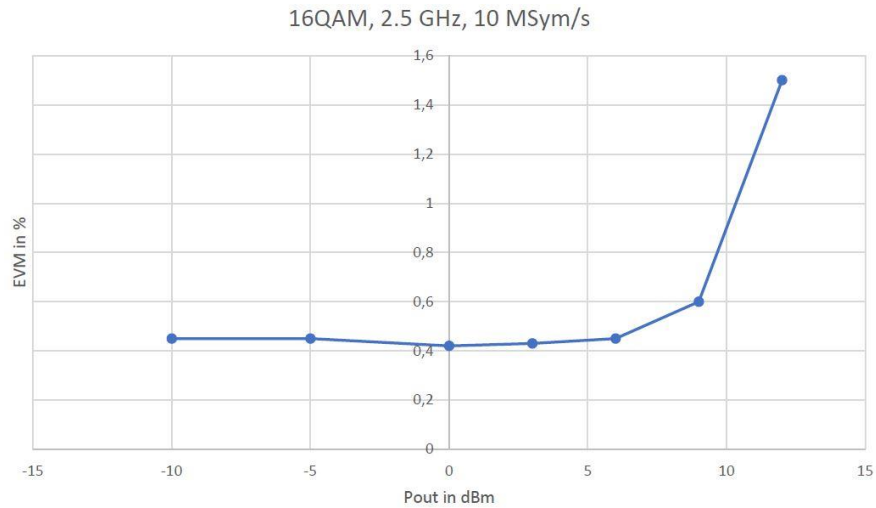

**Figure 33: EMV vs. Symbol Rate, 16QAM**

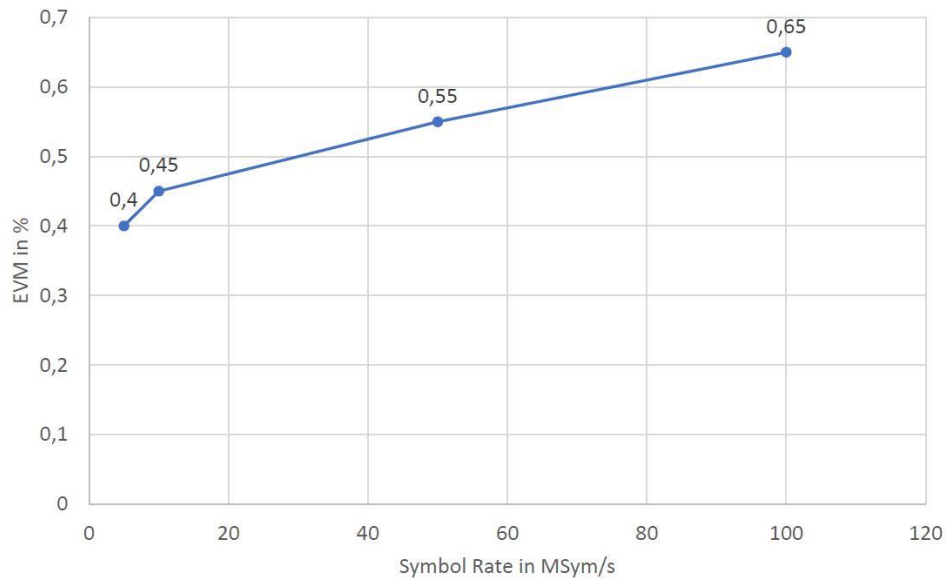

**Figure 34: EMV vs. RF Frequency, 16QAM, 10 MSymbols/s**

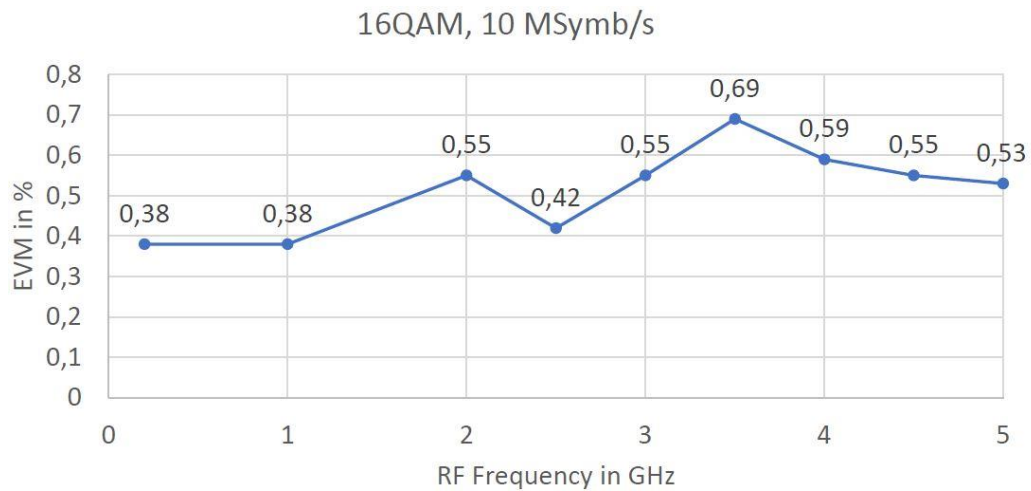

# Multicarrier Generation (Option IVM)

PARAMETER	MIN	TYPICAL	MAX	NOTE
Number of Carrier	1		1 k	
Frequency Offset	-200 MHz		200 MHz	
Power Offset	-60 dB		0 dB	0.1 dB resolution
Tone Initial Phase Offset	0 deg		360 deg	0.1 deg resolution

**Figure 35: 64-tone 400 MHz Bandwidth Signal**

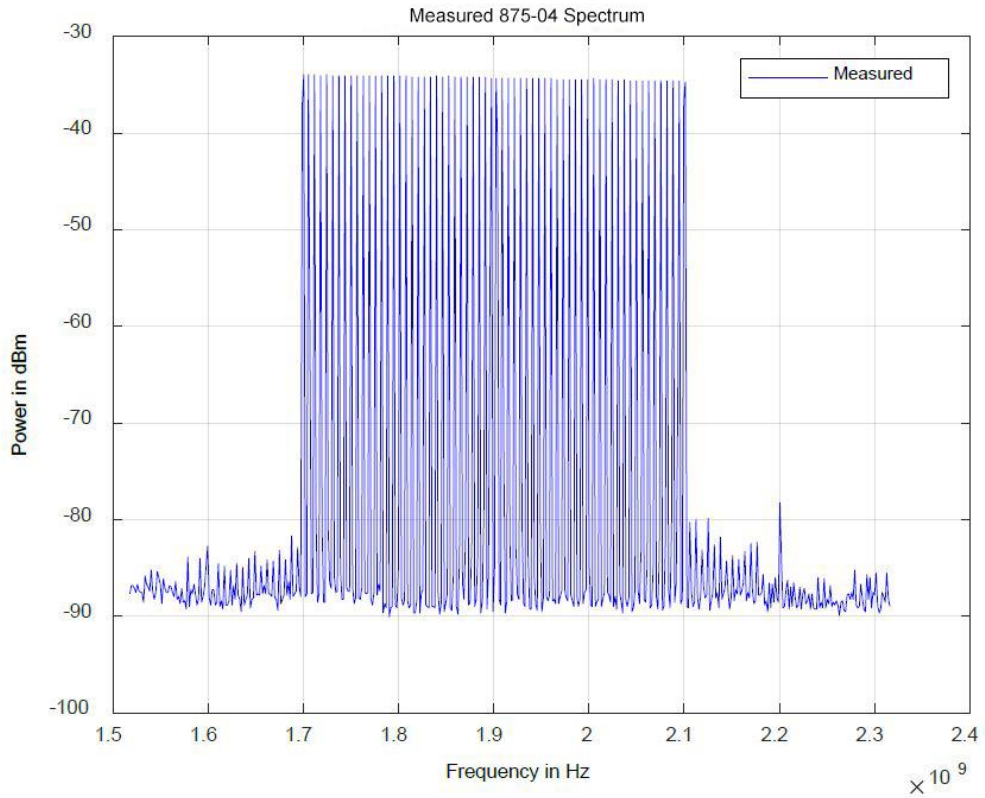

**Figure 36: Two-tone Sideband Rejection**

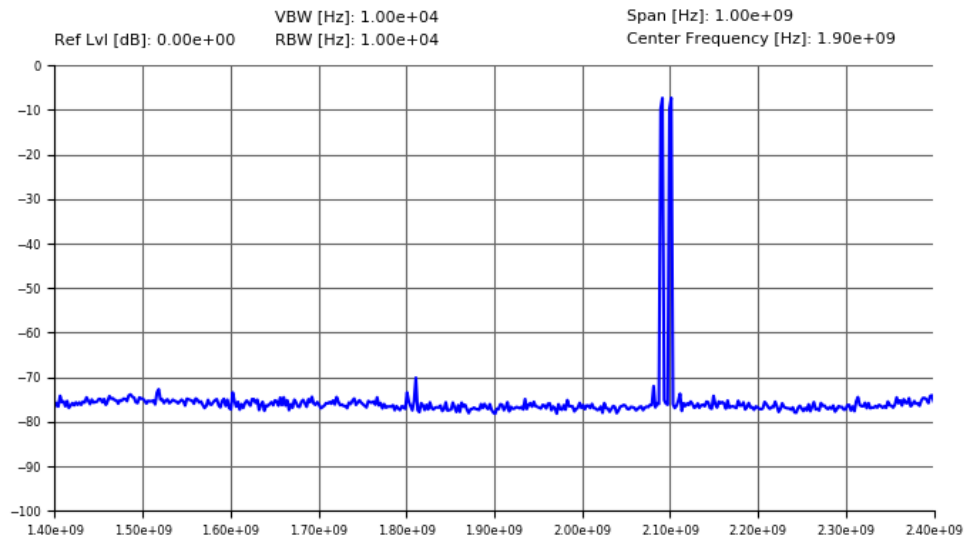

## DME Modulation (Option AVIO)

PARAMETER	MIN	TYPICAL	MAX	NOTE
<b>DME Modulation</b>				
Operating Modes	Interrogation & reply			
DME Channel	X, Y			
Frequency Range	960 MHz		1215 MHz	
Pulse pattern repetition rate	10 Hz		5000 Hz	
Pulse pattern repetition resolution		0.1 Hz		
Pulse pattern repetition accuracy			+/- 0.1 Hz	
Pulse-to-pulse level range	-80 dB		+80 dB	
Pulse-to-pulse level accuracy			+/- 0.2 dB	
Pulse on/off ratio	80 dB	100 dB		
<b>Main pulse pair</b>				Up to 4 additional pulses/pairs
Main pulse width	100 ns		100 μs	
Main pulse resolution		0.1 ns		
Main pulse accuracy		+/- 1 ns	+/- 17 ns	
Main pulse rise/fall time	100 ns		100 μs	
Main pulse rise/fall time resolution		0.1 ns		
Main pulse rise/fall time accuracy			+/- 17 ns	
Main pulse pair spacing	100 ns		100 μs	
Main pulse spacing resolution		0.1 ns		
Main pulse spacing accuracy			+/- 17 ns	
<b>Echo pulse pairs</b>				
Echo delay	2000 ns		8000 ns	
Echo delay resolution		0.1 ns		
Echo delay accuracy			+/- 17 ns	
Echo attenuation range	-3 dB		+12 dB	
Echo attenuation resolution		0.001 dB		
Echo attenuation accuracy			+/- 0.1 dB	
<b>Interference</b>				
Interference delay	1000 ns		8000 ns	
Interference delay resolution		0.1 ns		
Interference delay accuracy			+/- 17 ns	
Interference attenuation range	0 dB		+30 dB	
Interference attenuation resolution		0.001 dB		
Interference attenuation accuracy			+/- 0.2 dB	
<b>Receiver dead time test pulse pair</b>				
Delay	10 μs		100 μs	
Resolution		0.1 ns		
Accuracy			+/- 17 ns	
<b>Identification code transmission</b>	Repetition period, Morse dot length			3 characters code

## VOR Modulation (Option AVIO)

PARAMETER	MIN	TYPICAL	MAX	NOTE
Frequency range	108 MHz		118 MHz	Specification valid for carrier frequency range
VOR state	On/Off			
Bearing direction		From/To		
Bearing Accuracy			+/- 0.75°	
<b>AM0 component</b>				Nominal 30 Hz navigation variable signal
State	On/Off			
AM depth range	0		50%	
AM range resolution		0.01%		
AM accuracy			+/- 0.5%	
AM distortion (THD)			2%	
<b>AM1 component</b>				9,960 Hz navigation reference subcarrier
State	On/Off			
AM depth range	0		50%	
AM range resolution		0.01%		
AM accuracy			+/- 0.5%	
AM frequency	5000 Hz		15000 Hz	

AM frequency resolution		0.1		
AM frequency accuracy			+/- 1 mHz	
AM distortion (THD)			2%	
<b>FM component</b>				Nominal 30 Hz navigation reference signal
FM index	0		33.3	
FM index resolution		0.01		
FM index accuracy			+/- 0.033	
FM deviation accuracy 480 Hz			1 Hz	
<b>Identification code component</b>				4 characters code
State		On/Off		
AM frequency	300 Hz		1740 Hz	
AM frequency resolution		0.1 Hz		
AM frequency accuracy			+/- 1mHz	
AM depths	0		50%	
AM depths resolution		0.01%		
AM depths accuracy	0		+/- 0.5%	

### ILS Modulation (Option AVIO)

PARAMETER	MIN	TYPICAL	MAX	NOTE
ILS modulation	Generation of ILS Localizer signal			ILS-LOC
<b>ILS LOC</b>	Generation of ILS glidescope signal			ILS-GS
Frequency range	108 MHz		118 MHz	Specification valid for carrier frequency range
DDM range	-193.5 $\mu$ A		+193.5 $\mu$ A	
DDM resolution		0.1 $\mu$ A		
DDM accuracy			+/- 4.8 $\mu$ A	
SDM range	20%		60%	
SDM resolution		0.01%		
SDM accuracy			+/- 1%	
<b>AM0 component</b>				Nominal 90 Hz left beam
Beam state		On/Off		
AM0 Depth (Change DDM/SDM)	10%		30%	
AM0 Depth resolution		0.01%		
AM0 depth accuracy			+/- 0.5 %	
Frequency in Hz	88 Hz		92 Hz	
Frequency resolution		0.0005 Hz		
Frequency accuracy			+/- 500 $\mu$ Hz	
<b>AM1 component</b>				Nominal 150 Hz right beam
Beam state		On/Off		
AM0 Depth (Change DDM/SDM)	10%		30%	
AM0 Depth resolution		0.01%		
AM depth accuracy			+/- 0.5%	
Frequency in Hz	147 Hz		154 Hz	
Frequency resolution		0.0005 Hz		
Frequency accuracy			+/- 500 $\mu$ Hz	
Range of relative phase to AM0 component	0		360°	
Resolution of relative phase to AM0 component		0.001		
Accuracy of relative phase to AM0 component			+/- 1°	
<b>Identification code component</b>				4 characters code
Identification state		On/Off		
AM frequency	300 Hz		1740 Hz	
AM frequency resolution		0.0005 Hz		
AM frequency accuracy			+/- 500 $\mu$ Hz	
AM depth	0		50%	
AM depth resolution		0.01%		
AM depth accuracy			+/- 0.5%	
<b>ILS GS</b>				

Frequency range	329 MHz		335 MHz	Specification valid for carrier frequency range
DDM range	-342.8 $\mu$ A		+342.8 $\mu$ A	
DDM resolution		0.1 $\mu$ A		
DDM accuracy			+/- 4.8 $\mu$ A	
SDM range	40%		120%	
SDM resolution		0.01%		
SDM accuracy			+/- 1%	
<b>AM0 component</b>				Nominal 90 Hz upper beam
Beam state		On/Off		
AM0 Depth (Change DDM/SDM)	20%		60%	
AM0 Depth resolution		0.01%		
AM depth accuracy			+/- 0.5%	
Frequency in Hz	88 Hz		92 Hz	
Frequency resolution		0.0005 Hz		
Frequency accuracy			+/- 500 $\mu$ Hz	
<b>AM1 component</b>				Nominal 150 Hz lower beam
Beam state		On/Off		
AM1 Depth (Change DDM/SDM)	20%		60%	
AM1 Depth resolution		0.001%		
Frequency in Hz	147 Hz		154 Hz	
Frequency resolution		0.0005 Hz		
Frequency accuracy			+/- 500 $\mu$ Hz	
<b>AM1 component</b>				Nominal 150 Hz lower beam
Beam state		On/Off		
AM1 Depth (Change DDM/SDM)	20%		60%	
AM1 Depth resolution		0.01%		
AM1 Depth accuracy			+/- 0.5%	
Frequency in Hz	147 Hz		154 Hz	
Frequency resolution		0.0005		
Frequency accuracy			+/- 500 $\mu$ Hz	
Range of relative phase to AM0 component	0		360°	
Resolution of relative phase to AM0 component		0.001		
Accuracy of relative phase to AM0 component			+/- 1°	

## Marker Beacon (Option AVIO)

PARAMETER	MIN	TYPICAL	MAX	NOTE
AM Tone Accuracy (95% AM)		5% of setting		
AM Tone Distortion (95% AM)		5%		

Figure 37: DME Spectrum (X Channel, Raised Cosine Filter)

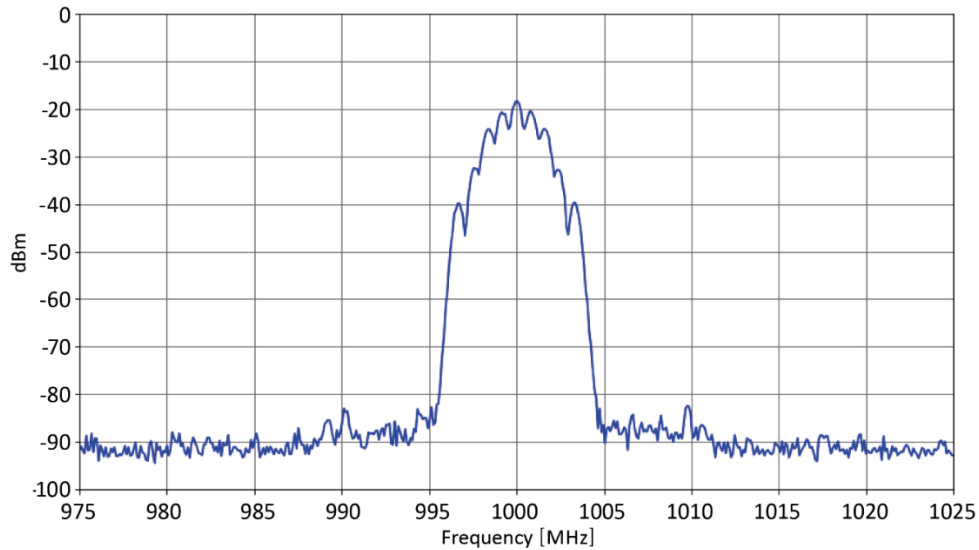

## Additive White Gaussian Noise (Option AWGN)

PARAMETER	MIN	TYPICAL	MAX	NOTE
<b>Noise</b>				
Distribution Density	Gaussian, statistical, $\mu = 0, \sigma^2 = 1$			Separate for I and Q
Crest Factor	$\leq 21.07$ dB			Depending on C/N ratio
Periodicity	$> 7 \times 10^{44}$ s			
<b>Carrier to Noise Ratio C/N</b>				
Range	-60 dB		90 dB	Limited by the RF output power
Resolution		0.01 dB		See application note "AN6005"
<b>Noise Bandwidth</b>				
Dependency	0.8 of I/Q baseband generator sample rate Manually			Any modulation active All modulations inactive
Range	10 Hz		400 MHz	
Resolution	1 Hz			
<b>Power Control Mode</b>				
	Total, carrier, noise			

## Trigger Capability

PARAMETER	MIN	TYPICAL	MAX	NOTE
Trigger Mode	Single, continuous			
Trigger Source	Internal (Immediate, bus), external			
<b>External Trigger Input</b>				
Connector Type	MF1 IN, MF2 IN			See chapter "External Multi-Function Inputs"
Delay Setting Range	0 s		8.5 s	
Delay Setting Resolution		2 ns		
Jitter		$\pm 2$ ns		
Slope	Rising, falling			
<b>Trigger Output</b>				
Connector Type	MF1 OUT, MF2 OUT			See chapter "External Multi-Function Output"

Polarity	Normal, inverted		
Delay Setting Range	0 s		2 $\mu$ s
Delay Setting Resolution		2 ns	
Pulse Width Setting Range	8 ns		16 $\mu$ s
Pulse Width Setting Resolution		8 ns	

## External Multi-Function Inputs

PARAMETER	MIN	TYPICAL	MAX	NOTE
Connector	MF1 IN, MF2 IN			See chapters "CONNECTORS"
Application	External pulse modulation, External trigger			
Nominal Input Impedance	DC 10 k $\Omega$ and AC 50 $\Omega$			
Threshold Voltage	0.85 V	0.9 V	0.95 V	
Nominal Input Voltage	0 V		3.3 V	TTL compatible
Hysteresis		60 mV		

## External Multi-Function Outputs

PARAMETER	MIN	TYPICAL	MAX	NOTE
Connector	MF1 IN, MF2 IN			See chapters "CONNECTORS"
Application	Pulse video signal, trigger, marker signals (1-4)			
Nominal Output Impedance	tbd			
Nominal Output Voltage	0 V		3.3 V	LVTTTL

## Fast Control Port (Option FCP)

PARAMETER	NOTE																																				
Interface	Parallel, bidirectional LVDS with 100 $\Omega$ termination at receiver																																				
Common Mode Level	Typ. 1.2 V																																				
Differential Input Threshold	Typ. +/- 100 mV																																				
Differential Output Voltage	Typ. 300 mV																																				
Connector	FCP I/O – see chapter "CONNECTORS"																																				
Mode: I/Q Data Streaming																																					
Sample Rate ()	125 and 250 MHz																																				
Input/Output Format	data (16 bits), clock signal, valid signal																																				
Valid I/Q Data Input to RF Output Delay	typ. tbd ns																																				
Mode: Segment ID Streaming																																					
Input Format	data (16 bits), valid signal (signal must be static low or high)																																				
Valid Segment ID Input to RF Output Delay (immediate segment changeover)	typ. tbd ns																																				
Valid Segment ID Jitter	+/- 8 ns																																				
Mode: CDW Streaming	875-04 Option FCP & UFS CDW is an operating mode of the 875 which takes control of the RF output. Other 875 features cannot be used simultaneously unless their settings are available as CDW parameters.																																				
Parameter	Frequency (up to 48 bit), power, phase, segment ID																																				
Parameter Range and Resolution	See chapter "PDW"																																				
Input Format	Address (8 bits), data (8 bits), valid signal																																				
Sampling Rate	250 MHz																																				
Valid signal level min. period	8 ns																																				
Data to valid setup and hold time	4 ns																																				
Automatic Level Control (ALC) Mode	OFF																																				
Pin Assignment	<table border="1"> <thead> <tr> <th>Pin (P/N)</th> <th>Signal</th> <th>Pin (P/N)</th> <th>Signal</th> <th>Pin (P/N)</th> <th>Signal</th> </tr> </thead> <tbody> <tr> <td>1/19</td> <td>Data bit 0</td> <td>2/20</td> <td>Data bit 1</td> <td>3/21</td> <td>Data bit 2</td> </tr> <tr> <td>4/22</td> <td>Data bit 3</td> <td>5/23</td> <td>Data bit 4</td> <td>6/24</td> <td>Data bit 5</td> </tr> <tr> <td>7/25</td> <td>Data bit 6</td> <td>8/26</td> <td>Data bit 7</td> <td>9/27</td> <td>Data bit 8</td> </tr> <tr> <td>10/28</td> <td>Data bit 9</td> <td>11/29</td> <td>Data bit 10</td> <td>12/30</td> <td>Data bit 11</td> </tr> <tr> <td>10/31</td> <td>Data bit 12</td> <td>14/32</td> <td>Data bit 13</td> <td>15/33</td> <td>Data bit 14</td> </tr> </tbody> </table>	Pin (P/N)	Signal	Pin (P/N)	Signal	Pin (P/N)	Signal	1/19	Data bit 0	2/20	Data bit 1	3/21	Data bit 2	4/22	Data bit 3	5/23	Data bit 4	6/24	Data bit 5	7/25	Data bit 6	8/26	Data bit 7	9/27	Data bit 8	10/28	Data bit 9	11/29	Data bit 10	12/30	Data bit 11	10/31	Data bit 12	14/32	Data bit 13	15/33	Data bit 14
Pin (P/N)	Signal	Pin (P/N)	Signal	Pin (P/N)	Signal																																
1/19	Data bit 0	2/20	Data bit 1	3/21	Data bit 2																																
4/22	Data bit 3	5/23	Data bit 4	6/24	Data bit 5																																
7/25	Data bit 6	8/26	Data bit 7	9/27	Data bit 8																																
10/28	Data bit 9	11/29	Data bit 10	12/30	Data bit 11																																
10/31	Data bit 12	14/32	Data bit 13	15/33	Data bit 14																																

16/34	Data bit 15	17/35	valid	18/36	clock
-------	-------------	-------	-------	-------	-------

## External Analog Inputs (Option AIQ)

PARAMETER	MIN	TYPICAL	MAX	NOTE
Connector	I IN, Q IN			See chapters "CONNECTORS"
Analog Bandwidth	50 MHz			
Maximum Input Voltage	-2 V		+2 V	
Nominal Input Voltage Range		+/- 0.5 V		90%
Input Impedance		50 Ω		
Additional Features	Individual gain and DC offset adjustment, overrange detection			
Application	Analog I/Q data modulation external AM, FM, PM modulation			Option AIQ Option AIQ & MOD

## SD Card (Option SD)

PARAMETER	
Supported SD	Up to 2 GB with FAT 12 or FAT 16
Supported SDHC	Up to 32 GB with FAT 32

Figure 38: Graphical User Interface

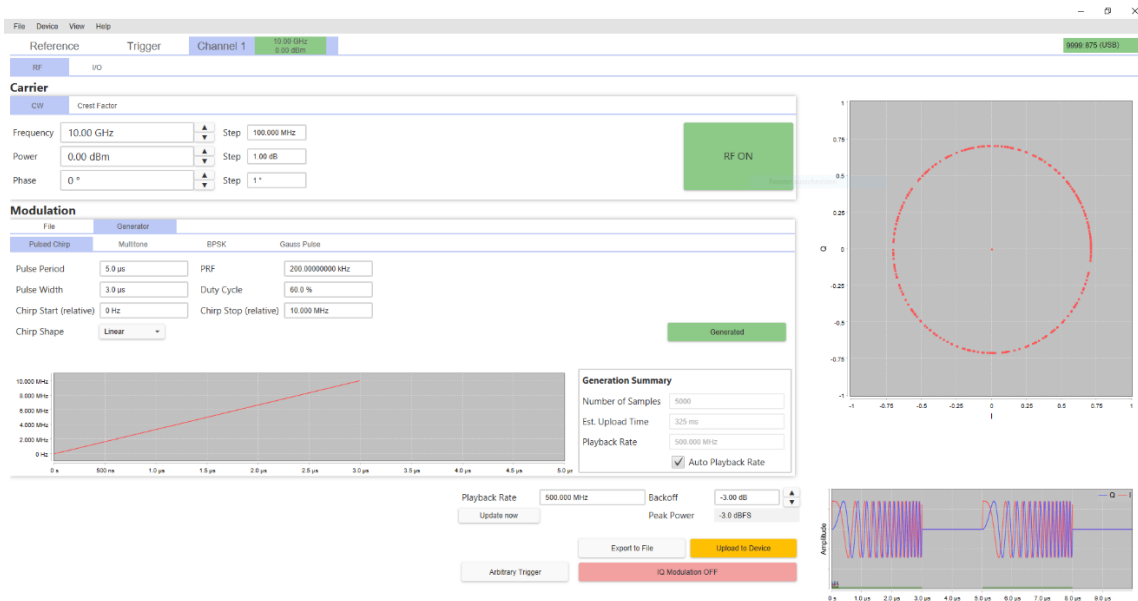

## CONNECTORS

### Front Panel (Single Channel Model):

LABEL	TYPE	DESCRIPTION	OPTION
RF 50 $\Omega$	Type N Female SMA Female K (2.92mm) Female	RF output	Model 875-4 / -6 / -12 Model 875-20 Model 875-40



### Rear Panel (Single Channel Model):

LABEL	TYPE	DESCRIPTION	OPTION
DC24V	DC power plug female	Power of Instrument	
	M4	Ground reference screw	
USB	USB type B	Remote programming interface	
LAN	RJ-45	Remote programming interface	
CLK IN	SMA, female	High-stability reference input	SYNC
CLK OUT	SMA, female	High-stability reference output	SYNC
SYNC IN, SYNC OUT	SMB, male	Multi-device synchronization ports	SYNC
SD	MicroSD	Card slot for non-volatile storage of I/Q data	
REF IN	BNC female	Reference frequency input	
REF OUT	BNC female	Reference frequency output	
MF1 IN, MF2 IN	SMB male	Multi-function digital inputs: User-configurable	
MF1 OUT, MF2 OUT	SMB male	Multi-function digital outputs: User-configurable	
I IN, Q IN	BNC female	Analog inputs: User-configurable	AIQ
FCP	36-pin mini-D female 3M MDR 102 Series	Fast control port, external digital I/Q data streaming (per channel)	FCP



## Front Panel (2U Multi-Channel Model):

LABEL	TYPE	DESCRIPTION	OPTION
<b>RF OUT</b> (for each channel)	SMA Female K (2.92mm) Female	RF output	875-20-X 875-40-X



## Rear Panel (2U Multi-Channel Model):

LABEL	TYPE	DESCRIPTION	OPTION
-	C13	Power of instrument	
	M4	Ground reference screw (earth)	
<b>USB</b>	USB type B	Remote programming interface	
<b>LAN</b>	RJ-45	Remote programming interface	
<b>GPIB</b>	24-pin female	Remote programming interface	
<b>SD</b>	MicroSD	Card slot for non-volatile storage of I/Q data	
<b>REF IN</b>	BNC female	Reference frequency input	
<b>REF OUT</b>	BNC female	Reference frequency output	
<b>CLK IN</b>	SMA female	High-stability reference input	SYNC
<b>CLK OUT</b>	SMA female	High-stability reference output	SYNC
<b>FCP</b> (for each channel)	36-pin mini-D female 3M MDR 102 Series	Fast control port	FCP
<b>MF1 IN, MF2 IN</b> (for each channel)	SMB male	Multi-function inputs: User-configurable	
<b>MF1 OUT, MF2 OUT</b> (for each channel)	SMB male	Multi-function outputs: User-configurable	
<b>I IN, Q IN</b> (for each channel)	SMB male	Analog inputs: User-configurable	AIQ
<b>SYNC IN, SYNC OUT</b>	SMB, male	Multi-device synchronization ports (not visible in rear view)	SYNC

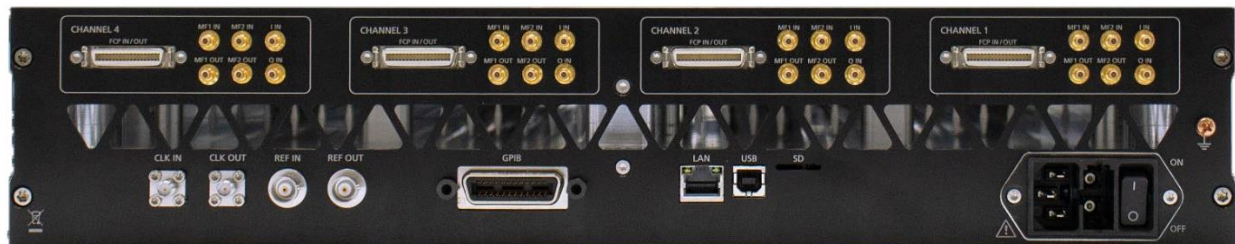

## ORDERING INFORMATION

HOST MODEL	PRODUCT	DESCRIPTION
875 Single channel model	875-04	4 GHz model
	875-06	6 GHz model
	875-12	12 GHz model
	875-20	20 GHz model
	875-40	40 GHz model
875-X 2U rack-mount model	875-04-X	4 GHz model
	875-06-X	6 GHz model
	875-12-X	12 GHz model
	875-20-X	20 GHz model
	875-40-X	40 GHz model

-X: channels = (1), 2, 3 or 4 channels

HARDWARE OPTIONS	PRODUCT	DESCRIPTION
875(-X)	Option LN	Enhanced close-in phase noise & frequency stability
875(-X)	Option LN+	Enhanced close in phase noise & further enhanced long term frequency stability
875(-X)	Option SYNC	Multi device synchronization ports
875(-X)	Option FCP	Fast control port, external digital I/Q data streaming (per channel)
875(-X)	Option AIQ	External analog I/Q inputs (per channel)
875	Option GPIB	GPIB interface
875(-X)	Option 100K	Frequency range extension to 100 kHz
875-04(-X) 875-06/12/20(-X) 875-40(-X)	Option PE4-04 Option PE4-20 Option PE4-40	Electronic step attenuator
875-04/06/12/20(-X) 875-40(-X)	Option PE-20 Option PE-40	Mechanical step attenuator (down to -90 dBm)
875-04/06/12/20(-X) 875-40(-X)	Option PE2-20 Option PE2-40	Mechanical step attenuator (down to -120 dBm)
875-06/12/20(-X)	Option FILT-20	Harmonic filtering (per channel), option PE4-XX required
875-40(-X)	Option FILT-40	Harmonic filtering (per channel), option PE4-XX required

SOFTWARE LICENSES	PRODUCT	DESCRIPTION
875(-X)	Option UFS	Ultra-fast switching speed
875(-X)	Option PHS	Phase-coherent switching
875(-X)	Option PCM	Firmware for "Phase Calibratable Mode" (per channel), option PHS required
875(-X)	Option PDW	Pulse descriptor word (per channel)
875(-X)	Option MOD	Internal analog modulations
875(-X)	Option IVIM	Internal digital modulation schemes (per channel)
875(-X)	Option AVIO	Internal avionic modulations (per channel)
875(-X)	Option AWGN	Additive white gaussian noise generator (per channel)
875(-X)	Option SD	MicroSD card support for non-volatile storage of I/Q data
875(-X)	Option VREF	Variable external reference

ACCESSORIES	PRODUCT	DESCRIPTION
875	Option EB	External Battery with adapter cable

## GENERAL CHARACTERISTICS

## Remote Programming Interfaces:

- Ethernet 100BaseT LAN Interface
- USB 2.0 Device Interface
- GPIB (IEEE-488.2, 1987) with listen and talk (Option GPIB)
- Control Language: SCPI Version 1999.0

## Power requirements

### Single Channel Model

Input Voltage Range	24 VDC $\pm$ 3.0 V	
Power Consumption (typ) (without Options)	45W 65W	875-04 875-06 to 875-40
Main Adapter supplied (without Options)	100 - 240 VAC 50/60Hz; 24 VDC and 65W max	875-04
	100 - 240 VAC 50/60Hz; 24 VDC and 160 W max	875-06 to 875-40
Multi-Channel Model		
Input Voltage Range	100 - 240 VAC 50/60Hz	
Fuse Rating	5x20mm, 250 V, 6.3 AT	2-poles, each
Power Consumption (max)	200 W  400 W	875-04-X, 875-06-X, 875-12-2, 875-20-2, 875-40-2, 875-06-2, 875-12-04 875-20-4, 875-40-4

**Environmental** (Levels similar to MIL-PRF-28800F Class 3/4) Environmental stress Samples of this product have been type tested to be robust against the environmental stresses of storage, transportation, and end-use; those stresses to temperature, humidity, shock, vibration, altitude, and power line conditions.

**Operating temperature range:** 0 to 45 °C

**Storage temperature range:** -40 to 70 °C

**Operating and storage altitude** up to 15,000 feet (4600 m)

## ⚠ Notice

**EMC** complies to EMC regulations and directives for emission and immunity to interference (EN 61326-1 Industrial, EN/IEC 61326-2-1).

**Safety** complies to applicable safety regulation IEC/EN 61010-1.

This product complies with directive 2011/65/EU.

### Single-channel (portable / benchtop)

#### Weight:

6 lbs [2.7 kg] to 9.7 lbs [4.4 kg] net without main adapter

#### Dimensions:

Incl. rubber: 4.88 in H x 7.17 in W x 11.85 in L [124 mm H x 182 mm W x 301 mm L]  
With RF output connector type N: 4.88 in H x 7.17 in W x 12.20 in L [124 mm H x 182 mm W x 310 mm L]

### Multi-channel (rack-mountable) 19" 2HU enclosure

#### Weight:

37 lbs [18 kg] net,  $\leq$  55 lbs [25 kg] shipping

#### Dimensions:

Body: 3.39 in H x 17.5 in W x 22.5 in L [86 mm H x 444 mm W x 572mm L]

**Recommended calibration cycle: 24 months**

## Document History

Version	Date	Author	Notes
V110	2019-10-28	Jk	update
V111	2020-02-20	Yg/jk	Update
V113	2020-03-31	Jk	Analog modulations revised, option EI/Q added, measurement plot added
V114	2020-04-31	Jk	New plots added
V120	2020-11-10	Jk	Extended to multi-channel, 12 GHz model
V121	2021-1-10	Jk	Power specs refined, data plots added
V122	2021-05-03	Rp	Pulse modulation, marker, multi-function in/outputs specs refined
V123	2021-06-21	Ee	Updated product images
V124	2021-06-25	Jk	Refined power ranges
V125	2021-07-20	Rp	Updated FCP/baseband generator
V126	2022-02-04	Jk	Plot update
V127	2022-03-21	Jk/rp	Update
V128	2022-03-29	Jk Ee	Option PE2 for 875-06/12, Option PE4, Option LN+, Reference bypass info Updated product images
V129	2022-10-29	Jk	Phase noise data refined
V130	2023-03-30	Rp Re	Update on sweep data, SD card, internal pulse generator Option PDW added
V131	2023-12-08	Ap	Added harmonics plot for 875-06
V132	2024-07-16	AT	Added new enclosure, AVIO modulation data refined

## Berkeley Nucleonics

2955 Kerner Blvd.  
San Rafael, CA 94901

Phone: 415-453-9955  
Email: [info@berkeleynucleonics.com](mailto:info@berkeleynucleonics.com)

[berkeleynucleonics.com](http://berkeleynucleonics.com)  
[berkeleynucleonics.com/downloads](http://berkeleynucleonics.com/downloads)

