

# AT1125, AT1125A Radiation Monitors

**Rapid radiation background measurement and instant response to its change**

**Express-monitoring of radionuclides in raw products, materials and environmental objects**

**Measurement of alpha and beta particle flux density from contaminated surfaces**

Portable high-sensitivity Radiation Monitors are designed to search for and detect sources of gamma radiation, measure ambient gamma radiation dose equivalent rate, alpha and beta particle flux density from flat contaminated surfaces, as well as for radiometric monitoring of radionuclides in samples using 0.5-litre Marinelli beaker.

For radiometric radionuclide content monitoring in samples the following monitor design variants are possible:

- 1)  $^{137}\text{Cs}$  monitoring
- 2)  $^{137}\text{Cs}$ ,  $^{134}\text{Cs}$  +  $^{137}\text{Cs}$  monitoring
- 3)  $^{131}\text{I}$ ,  $^{137}\text{Cs}$ ,  $^{134}\text{Cs}$  +  $^{137}\text{Cs}$  monitoring



## Applications

- Search, detection and localization of ionizing radiation sources
- Radiation monitoring of environment, areas, facilities, raw products and materials
- Rapid radiation monitoring of  $^{137}\text{Cs}$  content in wild-growing mushrooms and berries
- Dosimetric and Radiometric monitoring of manufacturing facilities
- Scrap metal radiation monitoring

## Features

- Multiple functions
- High sensitivity
- Field operation capability over a wide temperature range
- Integrated system for measurement path LED stabilization
- Threshold level crossing alarm
- Memory function for up to 100 measurement results
- Writing, storing and transmitting measurement data into PC via RS232 or USB (adapter) interface

## Operating principle

It is equipped with NaI(Tl) scintillation detector of high sensitivity and is able to rapidly respond to minor changes in radiation background. "Spectrum-Dose" correction functions in energy range from 0.05 to 3 MeV allows high-accuracy dose rate measurement in a wide range of gamma energies.

Apart from scintillation detector AT1125A Radiation Monitor is equipped with a Geiger-Muller tube, that significantly expands the range of ambient gamma radiation dose equivalent rate measurement.

This device features a possibility of sample radiometric radionuclide content monitoring with lead protecting unit indoors and express-testing in field environment without lead protecting unit.



External BDPS-02 detection unit connection



The Radiation Monitors can be delivered with an external BDPS-02 detection unit, designed for measuring alpha and beta particle flux density from flat contaminated surfaces, gamma and X-radiation ambient dose equivalent and ambient dose equivalent rate.



**ATOMTEX**<sup>®</sup>

INSTRUMENTS AND TECHNOLOGIES FOR NUCLEAR MEASUREMENTS AND RADIATION MONITORING

# AT1125, AT1125A Radiation Monitors

## Specification

<b>Detector</b>	
AT1125	Scintillator NaI(Tl) Ø25x40mm
AT1125A	Scintillator NaI(Tl) Ø25x40mm, Integrated Geiger-Muller counter tube
BDPS-02	End-type Geiger-Muller counter tube
<b>Ambient gamma and X radiation dose rate equivalent measurement range</b>	
AT1125	30 nSv/h – 300 µSv/h
AT1125A	30 nSv/h – 100 mSv/h
BDPS-02	0.1 µSv/h – 30 mSv/h
<b>Ambient gamma and X radiation dose equivalent measurement range</b>	
AT1125	10 nSv – 10mSv
AT1125A	10 nSv – 10Sv
BDPS-02	0.1 µSv – 1 Sv
<b>Limits of tolerable intrinsic relative error of dose rate and dose measurement</b>	
AT1125, AT1125A	±15%
BDPS-02	±20%
<b>Energy range of registered X-ray and gamma radiation</b>	
AT1125, AT1125A	50 keV – 3 MeV
BDPS-02	20 keV – 3 MeV
<b>Typical sensitivity</b>	
AT1125, AT1125A	
For <sup>137</sup> Cs	350 cps/µSv·h <sup>-1</sup>
For <sup>241</sup> Am	3800 cps/µSv·h <sup>-1</sup>
BDPS-02 for <sup>137</sup> Cs	6.6 cps/µSv·h <sup>-1</sup>
<b>Energy dependence relative to 662 keV (<sup>137</sup>Cs)</b>	
AT1125, AT1125A	±15%
BDPS-02	±30%
<b>Response time for dose rate change from 0.1 to 1 µSv/h</b>	≤2 s (accuracy error ≤±10%)
<b>Natural radiation background (0.1µSv/h) measurement time with ±20% statistical error (P=0.95)</b>	≤15 s
<b>Detection time of <sup>137</sup>Cs source with 10 kBq activity at 5 cm distance</b>	<2 s
<b>Count rate measurement range</b>	1 – 10 <sup>5</sup> s <sup>-1</sup>
<b>Flux density measurement range</b>	
Alpha particles (BDPS-02)	2.4 – 1·10 <sup>6</sup> min <sup>-1</sup> ·cm <sup>-2</sup>
Beta particles (BDPS-02)	6 – 1·10 <sup>6</sup> min <sup>-1</sup> ·cm <sup>-2</sup>
<b>Spectrum maximum energy range of registered beta particles (BDPS-02)</b>	155 keV – 3.54 MeV
<b><sup>137</sup>Cs specific activity measurement range with 0.5 litre Marinelli beaker</b>	
<i>With Protection Unit</i>	50 – 10 <sup>5</sup> Bq/kg
<i>W/o Protection Unit</i>	100 – 10 <sup>5</sup> Bq/kg
<b>Limits of tolerable intrinsic relative error of <sup>137</sup>Cs specific activity measurement</b>	±20%
<b>Power supply</b>	Internal rechargeable Ni-MH battery or AC power adapter

Design and specifications are subject to change without notice

<b>Burn-up life</b>	≥100 Sv
<b>Continuous run time on integrated battery set</b>	≥24h
<b>Operation mode setup time</b>	1min
<b>Protection class</b>	
AT1125	IP54
BDPS-02	IP64
<b>Working temperature range</b>	-20°C to +50°C
<b>Relative humidity with air temperature ≤35°C without condensation</b>	≤90%
<b>Overall dimensions, weight</b>	
AT1125, AT1125A	258x85x67 mm, 1.0 kg
BDPS-02	138x86x60 mm, 0.3 kg
Protection unit	200x200x410 mm, 12 kg

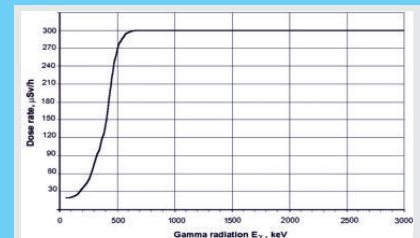

Normal relationship between upper limit of dose rate measuring range and gamma radiation energy of scintillation detection channel

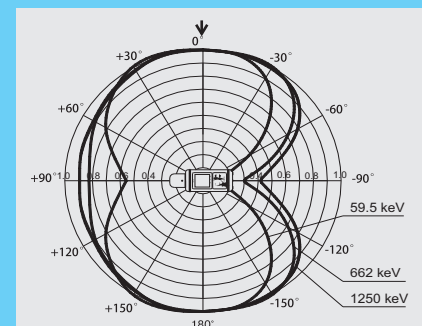

Normal radiation monitor anisotropy

The radiation monitors comply with:  
GOST 27451-87,  
Safety requirements of IEC 61010-1:2010,  
EMC requirements of EN 55011:2009,  
IEC 61000-4-2:2008, IEC 61000-4-3:2008,  
IEC 61000-4-4:2004, IEC 61000-4-5:2005,  
IEC 61000-4-6:2008, IEC 61000-4-8:2009,  
IEC 61000-4-11:2004